

Stellanova

GXY944



Item no. GXY944012-3717

General Product Information

Dimensions LxWxH	208x209x115 cm
Age group	6+
Play capacity (users)	8
Colour options	

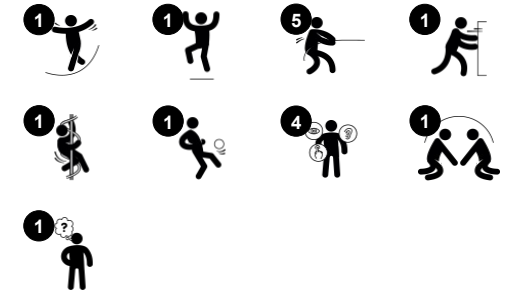

The Stellanova attracts bigger children and teens immensely with its whimsical roundabout impression. The ring of the Stella Nova can be spun by pushing and pulling it into motion, using the central pole handlebar. The pushing and pulling is great for upper body and core muscles. These muscles are often underused due to sedentary lifestyles. Keeping equilibrium

when rotating is a great training of the sense of balance. In the tween and teenage years, the sense of balance needs extra training because of the growth spurt of the children. The ring of the Stellanova is parted into sections, defining individual or team space. The many rules games that children invent on the Stellanova stimulate cooperation and negotiation. This

makes the Stellanova a great venue of training social-emotional skills.

Stellanova

GXY944



The Stellanova is designed with 5 legs with hot dip galvanised surfacing treatment. The galvanisation has excellent corrosion resistance in outside environments and requires low maintenance.

To support the play and count revolutions while turning one of the ring segments or one of the connector brackets or ring segment is made in a different colour.



The 7 ring segments are made of low density PE with excellent impact strength and usable within a large temperature span. Each segment has integrated handholds on both sides and non-skid top surface for safe usage.

Item no. GXY944012-3717

Installation Information

Max. fall height	100 cm
Safety surfacing area	29.2 m ²
Number of installers	2
Total installation time	5.0
Excavation volume	1.15 m ³
Concrete volume	0.00 m ³
Footing depth (standard)	90 cm
Shipment weight	355 kg
Anchoring options	In-ground ✓ Surface ✓

Warranty Information

Hot dip galvanised steel	Lifetime
PUR components	10 years
Hollow PE parts	10 years
Ropes & nets	10 years
Spare parts guaranteed	10 years



The Supernova is designed with a lifetime lubricated maintenance free roller system of vertical and horizontal rollers. The roller system is fully closed and sealed by two rubber lists.



GreenLine versions in dark teal color are designed with molded PP parts which consist of 25% recycled post consumer waste and 75% virgin material. GreenLine ensures the lowest possible CO₂e emission factor.





Cradle to Gate A1-A3	Total CO ₂ emission	CO ₂ e/kg	Recycled materials
	kg CO ₂ e	kg CO ₂ e/kg	%
GXY944012-3717	512.50	2.74	38.90
GXY944021-3717	504.80	2.70	42.10

The overall framework applied for these factors is the Environmental Product Declaration (EPD), which quantifies "environmental information on the life cycle of a product and enable comparisons between products fulfilling the same function" (ISO, 2006). This follows the structure and applies a Life-Cycle Assessment approach to the entire Product stage from raw material through manufacturing (A1-A3))

Kompan A/S
 C.F. Tietgens Boulevard 32C
 DK-5220 Odense SØ
 Denmark



Validation of CO₂ calculation of: Freestanding play equipment



Data version no. 2021-09-27

The CO₂ calculation and data are in compliance with the principles of a carbon footprint impact according to the GHG protocol (Greenhouse Gas Protocol), Scope 3, cradle to gate related to all individual components in the product category: "Freestanding play equipment" represented by item no.: GXY916012-3417.

(Scope 3 emissions include emission sources in the upstream and downstream value chain).

Date: 15. October 2021 | Valid until: 15. October 2023

Validated by:

Bente Hviid, Senior Consultant

Peter Bendtsen, Senior Consultant

Validation based on report: Validation of CO₂ calculation of 8 categories of Kompan product line, version 1.0, prepared by: Bureau Veritas HSE, Denmark: Bente Hviid and Peter Bendtsen.

Publication date: 15. October 2021

By Bureau Veritas HSE
 www.bureauveritas.dk
 +45 7731 1000



* Max fall height | ** Total height | *** Safety surfacing area

* Max fall height | ** Total height

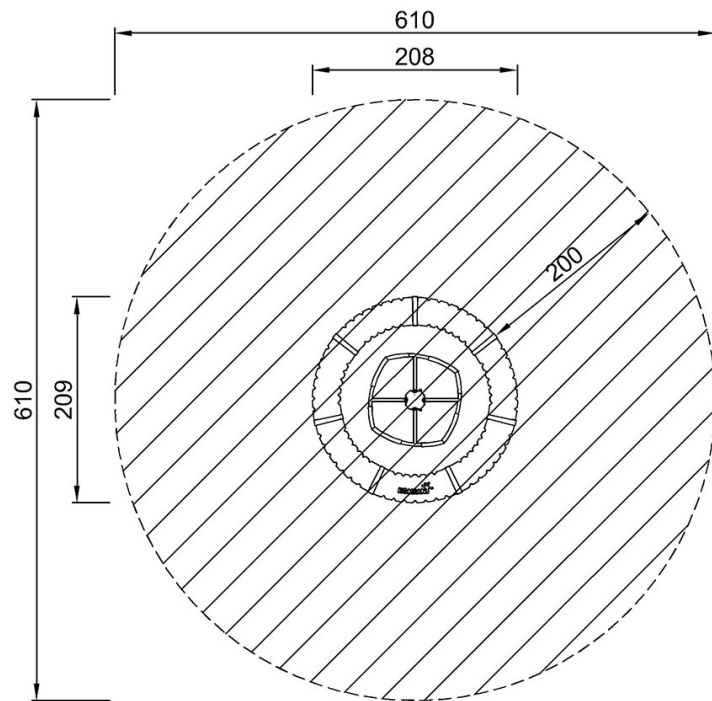

GXY944021
*100cm
**115cm
***29.2m²

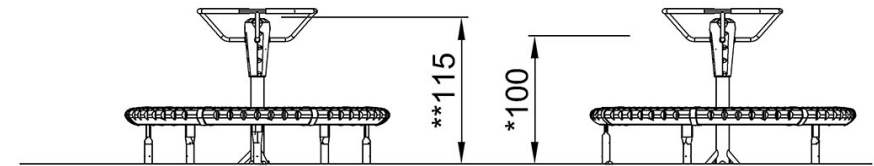

GXY944021

[Click to see TOP VIEW](#)

[Click to see SIDE VIEW](#)