

# PLAYHUT W/ SIDE+GABLE+DESKS

NRO413

**KOMPAN**  
Let's play



Item no. NRO413-1031

## General Product Information

Dimensions LxWxH	180 x 163 x 158 cm
Age Group	6m+
Play Capacity	10 children
Colour Options	 



A playhut easily attracts in younger children who just want to simply play. The simple yet intentional design and the detail in its features supports and enhances children's play. The wide open space allows for a flow of children in and around the play space. This increases social interactions and supports the children when they are looking for a way to interact with

others comfortably. The roof provides a sheltered space allowing the children to move in and out of the playhut while using their imagination. The fenced section of the house also creates an additional opportunity for play and movement around the playhut. The children can use this area to talk, socialise, to pass materials such as sand through and to

play hide and seek. The desk area adds another dimension to the play by providing a space for creating play themes that involve exchanges over the desks and through the open window space. All of these activities support a healthy development through play.



# PLAYHUT W/ SIDE+GABLE+DESKS

NRO413



All Organic Robinia products by KOMPAN are made of 100% Robinia wood. On request the products can be supplied with 100% FSC™ certification of the wood.



Products are PREASSEMBLED from the factory to ensure all safety requirements are considered.



The paint used for coloured components is water based environmentally friendly with excellent UV resistance. The paint is in compliance with EN 71 Part 3.

Item no. NRO413-1031	
Installation Information	
Max. fall height	- cm
Safety surfacing area	17,2 m <sup>2</sup>
Numbers of Installers (persons)	2
Total installation time	6
Excavation volume	0,63 m <sup>3</sup>
Concrete volume	0 m <sup>3</sup>
Footing Depth (Standard)	100 cm
Shipment Weight	249 kg
Anchoring options	In-ground ✓ Surface ✓
Warranty information	
Robinia wood	15 Years
Stainless steel hardware	Lifetime
Galvanised steel	10 Years
EcoCore™ HDPE	Lifetime
Spare parts guaranteed	10 Years



The playhouses are available with floor inside the house and with a floor outside to create a porch.



There are Multiple footing options for all products: Surface anchoring with steel footings and expansion bolts. Wood in-ground or steel in-ground footings.



The Robinia can be supplied with different surface treatment: Untreated Robinia wood, Brown transparent paint and Coloured components.



# PLAYHUT W/ SIDE+GABLE+DESKS

NRO413

Max fall height | Total height | Safety surfacing area

Max fall height | Total height

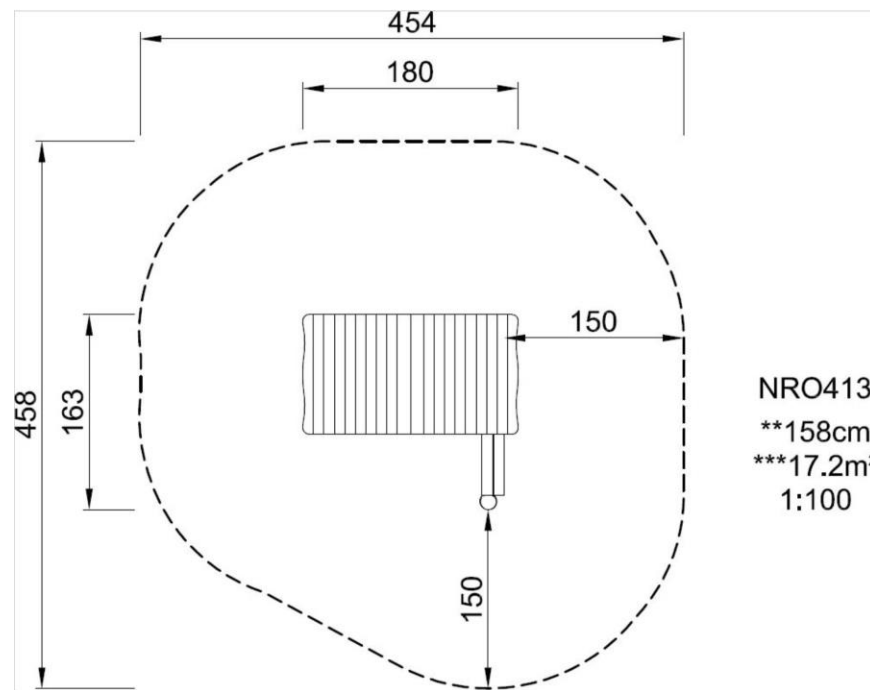

NRO413  
\*\*158cm  
\*\*\*17.2m<sup>2</sup>  
1:100

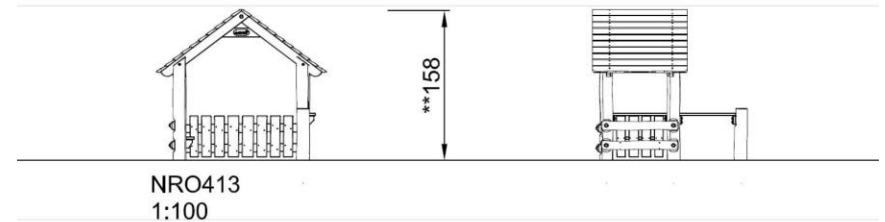

NRO413  
1:100

[Click to see 1:100 ratio TOP VIEW](#)

[Click to see 1:100 ratio SIDE VIEW](#)

# PLAYHUT W/ SIDE+GABLE+DESKS

NRO413



## Roof

**Cognitive:** suggests a theme and supports dramatic play, which stimulates languages and communication skills.



## Panel

**Social-Emotional:** creates a space for being together.



## Bench

**Social-Emotional:** gathering, cooperating or taking a break from play - all train social skills.



## Desk

**Social-Emotional:** great meeting place and space creator for storing or sitting.

# PLAYHUT W/ SIDE+GABLE+DESKS

NRO413



**PHYSICAL**  
Joy of movement:  
motor skills, muscle, cardio  
and bone density



**SOCIAL-EMOTIONAL**  
Joy of being together:  
teamwork, tolerance and  
sense of belonging



**COGNITIVE**  
Joy of learning:  
curiosity, understanding of causal  
relationships and knowledge of the world



**CREATIVE**  
Joy of creating:  
co-creation and experimenting  
with materials



**BALANCE**  
To balance is to stay upright when walking or standing on a surface that makes this challenging (e.g. a wobbly, inclined, or narrow surface).



**HANG IN ARMS**  
To hang in arms is the act of carrying the body with the hands or arms, possibly to traverse to another platform or play item.



**SENSORY**  
To sense is the act of taking in information with the sensory system: seeing, feeling, hearing or sensing with the body.



**BOUNCE**  
To bounce is the act of bouncing on a responsive, flexible, elastic or tensile surface.



**JUMP**  
To jump is the act of jumping up or down on a hard surface.



**SLIDE**  
To slide is the act of moving fast downwards seated on a slide.



**CLIMB**  
To climb is the act of moving upwards, cross-coordinating arms and legs, on a vertical or inclined surface or net.



**PULL**  
To pull is the act of pulling an item towards you or you towards an item with one or both hands, or possibly using the entire body.



**SOCIALIZE**  
To socialize is the act of meeting, communicating or cooperating in an activity that stimulates and facilitates social interaction.



**CONSTRUCT**  
To construct is the act of creating new patterns, shifting items or materials to new positions or constructing with materials that can be transformed or manipulated.



**PUSH**  
To push is the act of pushing an item away from you with one or both hands, possibly with the entire body.



**SPIN**  
To spin involves a fast, repeated horizontal or vertical turn of the body on a piece of equipment that facilitates the movement.



**CRAWL**  
To crawl is the movement of moving forwards or backwards, cross-coordinating arms and legs, on a horizontal or slightly inclined surface.



**ROCK**  
To rock is the action of rocking back and forth, or sideways, on e.g. a piece of spring equipment.



**SWAY**  
To sway is the movement of swaying back and forth, or around, lying, seated or possibly standing, in a pendulant or circular movement, e.g. on a hammock or on a rope.



**DRAMATIC PLAY**  
Dramatic play is motivated through play items that stage a frame, place or environment for acting out make believe or role play scenarios.



**ROTATE**  
To rotate involves a vertical or horizontal slower paced turn of the body, facilitated by a piece of equipment.



**SWING**  
To swing is the movement of swinging back and forth, or in circular movement, seated, standing or lying, in an unhindered arc.



**GLIDE**  
To glide is the act of moving from one point to another without shifting the feet, in a horizontal or vertical movement, in a seated, lying or standing position, letting gravity do the work.



**RULES PLAY**  
Rules play is motivated through play items that suggest games-with-rules, cooperation and team work, e.g. tic-tac-toe, timers or ball games.



**WONDER**  
To wonder is motivated through play items that make children need and use their logical, abstract or creative thinking skills, as well as their memory.