

# PERFORMER WITH SHADING

PCE105703



Item no. PCE105703-0903

## General Product Information

Dimensions LxWxH	385 x 292 x 390 cm
Age Group	2+
Play Capacity	6 children
Colour Options	

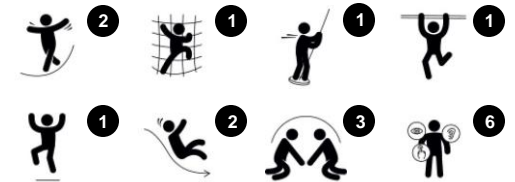

The Performer is a fantastic, slick play unit that will motivate social play again and again. The different activities support children's play and encourage richer play times. Children can climb and slide, along with friends, which supports social relationships and emotional understanding. After climbing up the smooth steps of the inclined climbing wall, using cross-

coordination and strength to get to the platform, the double slide is a rewarding way to return to the ground, alone or with a friend. This helps children to continue the play on every level. They will find the Performer a great meeting place for play, with all the variation within a small space. The Fireman's pole adds a thrill for more courageous children. It additionally trains

spatial awareness and adds a feeling of achievement when children dare to use it. This variety motivates play hugely.

# PERFORMER WITH SHADING

PCE105703



Panels of 19mm EcoCore™. EcoCore™ is a highly durable, eco-friendly material, which is not only recyclable after use, but also consists of a core produced from 100% recycled material.



The ELEMENTS roofs are made of recyclable PE with a minimum wall thickness of 5mm to ensure high durability in all climates around the world. The steel pipes are hot dip galvanized inside and outside for maximum durability.



Sails of commercial 95 high density PE knitted specially for sun-shade structures. The sails are treated with UV stabilizers to ensure a long life-time. The sails are supported by a hot dip galvanized steel frame and tightened by stainless steel devices.

Item no. PCE105703-0903	
Installation Information	
Max. fall height	88 cm
Safety surfacing area	22.5 m <sup>2</sup>
Numbers of Installers (persons)	2
Total installation time	10
Excavation volume	0.9 m <sup>3</sup>
Concrete volume	0.34 m <sup>3</sup>
Footing Depth (Standard)	85 cm
Shipment Weight	329 kg
Anchoring options	In-ground ✓
Warranty information	
EcoCore HDPE	Lifetime
Post	10 Years
HPL Decks	10 Years
Sun shading sails	5 Years
Spare parts guaranteed	10 Years



ELEMENTS decks are made of 17,8mm thick HPL supported by a unique designed aluminum frame with multiple attachment options by usage of aluminum connectors. The main posts are made of high quality pre-galvanized steel with powder coated top finish. Post tops are closed with plastic caps of UV stabilised nylon PA6.



The slides are available in either moulded PE in different colours or in full stainless steel AISI304 t=2 mm.



Steel activities are hot dip galvanized and optional with a powder coated top finish.



# PERFORMER WITH SHADING

PCE105703

Max fall height | Total height | Safety surfacing area

Max fall height | Total height

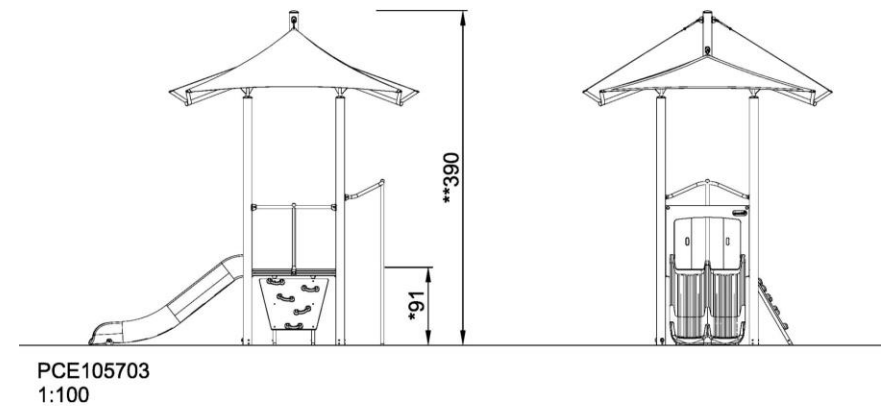
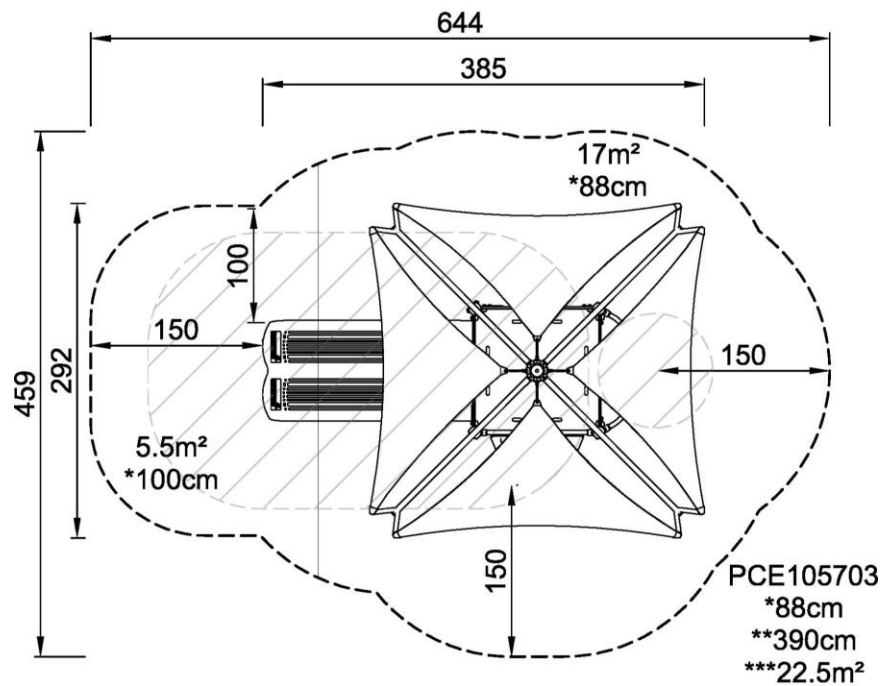

[Click to see 1:100 ratio TOP VIEW](#)

[Click to see 1:100 ratio SIDE VIEW](#)

# PERFORMER WITH SHADING

PCE105703



## Platform

**Social-Emotional:** the platform allows for more children to be together and share. Important life skills like courage, self-esteem, consideration and turn-taking are built.



## Double slide

**Physical:** sliding develops spatial awareness and a sense of balance. Furthermore, the core muscles are trained when sitting upright going down.

**Social-Emotional:** invites socializing, supports parent-child and peer-to-peer play.

**Cognitive:** young children train their understanding of space, speed and distances when sliding down quickly.

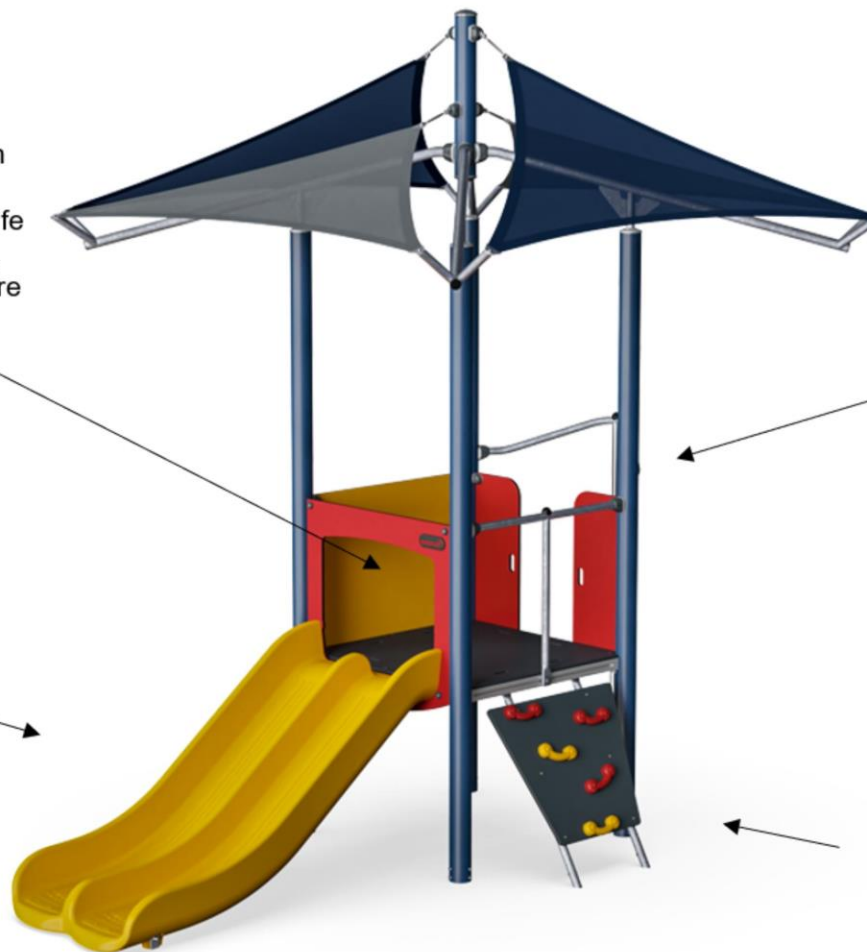

## Fireman's pole

**Physical:** coordination is supported when going down, as well as arm and core muscles. Landing strengthens bone density, which is built for life in childhood.

**Social-Emotional:** turn-taking and risk-taking.  
**Cognitive:** young children develop their understanding of space, speed and distances when gliding down fast.



## Rock climber

**Physical:** supports cross-coordination and leg, arm and hand strength.

**Social-Emotional:** the inclination makes climbing feel secure, especially for younger children.

# PERFORMER WITH SHADING

PCE105703



**PHYSICAL**  
Joy of movement:  
motor skills, muscle, cardio  
and bone density



**SOCIAL-EMOTIONAL**  
Joy of being together:  
teamwork, tolerance and  
sense of belonging



**COGNITIVE**  
Joy of learning:  
curiosity, understanding of causal  
relationships and knowledge of the world



**CREATIVE**  
Joy of creating:  
co-creation and experimenting  
with materials



**BALANCE**  
To balance is to stay upright when walking or standing on a surface that makes this challenging (e.g. a wobbly, inclined, or narrow surface).



**HANG IN ARMS**  
To hang in arms is the act of carrying the body with the hands or arms, possibly to traverse to another platform or play item.



**SENSORY**  
To sense is the act of taking in information with the sensory system: seeing, feeling, hearing or sensing with the body.



**BOUNCE**  
To bounce is the act of bouncing on a responsive, flexible, elastic or tensile surface.



**JUMP**  
To jump is the act of jumping up or down on a hard surface.



**SLIDE**  
To slide is the act of moving fast downwards seated on a slide.



**CLIMB**  
To climb is the act of moving upwards, cross-coordinating arms and legs, on a vertical or inclined surface or net.



**PULL**  
To pull is the act of pulling an item towards you or you towards an item with one or both hands, or possibly using the entire body.



**SOCIALIZE**  
To socialize is the act of meeting, communicating or cooperating in an activity that stimulates and facilitates social interaction.



**CONSTRUCT**  
To construct is the act of creating new patterns, shifting items or materials to new positions or constructing with materials that can be transformed or manipulated.



**PUSH**  
To push is the act of pushing an item away from you with one or both hands, possibly with the entire body.



**SPIN**  
To spin involves a fast, repeated horizontal or vertical turn of the body on a piece of equipment that facilitates the movement.



**CRAWL**  
To crawl is the movement of moving forwards or backwards, cross-coordinating arms and legs, on a horizontal or slightly inclined surface.



**ROCK**  
To rock is the action of rocking back and forth, or sideways, on e.g. a piece of spring equipment.



**SWAY**  
To sway is the movement of swaying back and forth, or around, lying, seated or possibly standing, in a pendulant or circular movement, e.g. on a hammock or on a rope.



**DRAMATIC PLAY**  
Dramatic play is motivated through play items that stage a frame, place or environment for acting out make believe or role play scenarios.



**ROTATE**  
To rotate involves a vertical or horizontal slower paced turn of the body, facilitated by a piece of equipment.



**SWING**  
To swing is the movement of swinging back and forth, or in circular movement, seated, standing or lying, in an unhindered arc.



**GLIDE**  
To glide is the act of moving from one point to another without shifting the feet, in a horizontal or vertical movement, in a seated, lying or standing position, letting gravity do the work.



**RULES PLAY**  
Rules play is motivated through play items that suggest games-with-rules, cooperation and team work, e.g. tic-tac-toe, timers or ball games.



**WONDER**  
To wonder is motivated through play items that make children need and use their logical, abstract or creative thinking skills, as well as their memory.