

MOTIVATOR WITH ROOF

PCE105802

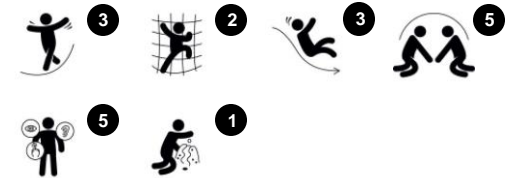

Item no. PCE105802-0903	
General Product Information	
Dimensions LxWxH	418 x 384 x 403 cm
Age Group	2+
Play Capacity	12 children
Colour Options	



The Motivator is a fantastic, slick play unit that will motivate social and physical play again and again. The varied activities support children's play and encourage richer playtimes. Children can climb and slide, along with friends, which supports social relationships and emotional compassion. After climbing up either of the steps, using cross-coordination and strength to

get to the platform, the varied slides offer rewarding ways to return to the ground, alone or with a friend. Sliding apart from training the sense of balance and the core muscles also make children continue to play. Children will find the Motivator great for meeting for play, with all the play variation. The Megaphone adds a social dimension when used to calling friends

to the Motivator for more play. The rich play variety in little space motivates play hugely.



MOTIVATOR WITH ROOF

PCE105802



Panels of 19mm EcoCore™. EcoCore™ is a highly durable, eco-friendly material, which is not only recyclable after use, but also consists of a core produced from 100% recycled material.



The ELEMENTS roofs are made of recyclable PE with a minimum wall thickness of 5mm to ensure high durability in all climates around the world. The steel pipes are hot dip galvanized inside and outside for maximum durability.



Sails of commercial 95 high density PE knitted specially for sun-shade structures. The sails are treated with UV stabilizers to ensure a long life-time. The sails are supported by a hot dip galvanized steel frame and tightened by stainless steel devices.

Item no. PCE105802-0903	
Installation Information	
Max. fall height	118 cm
Safety surfacing area	31.6 m ²
Numbers of Installers (persons)	2
Total installation time	16
Excavation volume	0.33 m ³
Concrete volume	0 m ³
Footing Depth (Standard)	85 cm
Shipment Weight	435 kg
Anchoring options	In-ground ✓
Warranty information	
Panels	Lifetime
Post	10 Years
Floors (decks)	10 Years
Sun shading sails	5 Years
Spare parts guaranteed	10 Years



ELEMENTS decks are made of 17,8mm thick HPL supported by a unique designed aluminum frame with multiple attachment options by usage of aluminum connectors. The main posts are made of high quality pre-galvanized steel with powder coated top finish. Post tops are closed with plastic caps of UV stabilised nylon PA6.



The slides are available in either moulded PE in different colours or in full stainless steel AISI304 t=2 mm.



Steel activities are hot dip galvanized and optional with a powder coated top finish.



MOTIVATOR WITH ROOF

PCE105802

Max fall height | Total height | Safety surfacing area

Max fall height | Total height

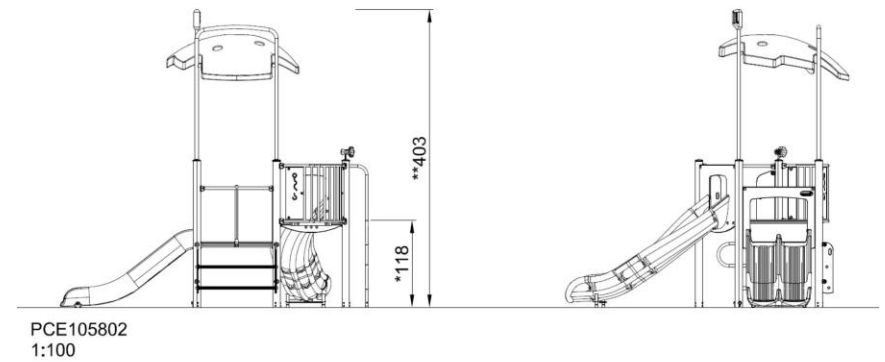
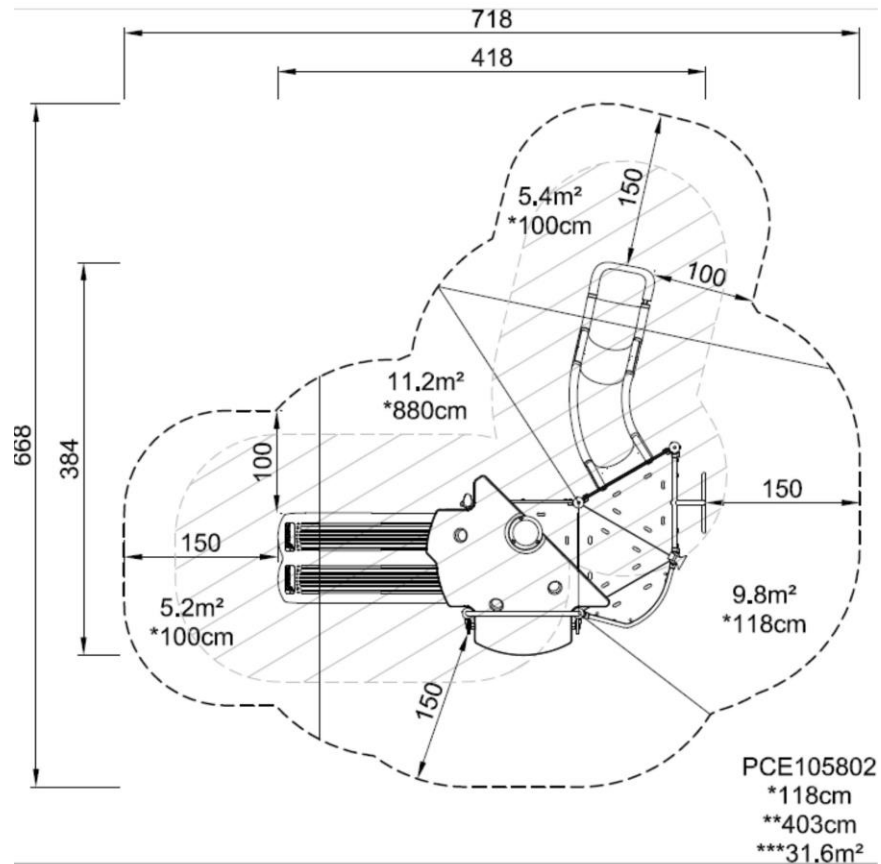

[Click to see 1:100 ratio TOP VIEW](#)

[Click to see 1:100 ratio SIDE VIEW](#)

MOTIVATOR WITH ROOF

PCE105802



Balcony

Social-Emotional: the balcony invites meetings and interaction with people on ground level.

Cognitive: invites dramatic play and performance, which stimulates language development.



Megaphone

Social-Emotional: inspires communication and turn-taking skills.

Cognitive: distortion of sound evokes curiosity and stimulates an understanding of cause and effect.



Climbing pole

Physical: cross-coordination and muscle strength are trained.

Social-Emotional: turn-taking and cooperation.



Pipe ladder

Physical: cross-coordination and eye-hand coordination are supported when children climb the ladder. The climbing also supports leg and arm muscles.

Social-Emotional: social interaction when hanging out together, learning about turn taking and cooperation.



Double slide

Physical: sliding develops spatial awareness and a sense of balance. Furthermore, the core muscles are trained when sitting upright going down.

Social-Emotional: invites socializing, supports parent-child and peer-to-peer play.

Cognitive: young children train their understanding of space, speed and distances when sliding down quickly.



MOTIVATOR WITH ROOF

PCE105802



PHYSICAL
Joy of movement:
motor skills, muscle, cardio
and bone density



SOCIAL-EMOTIONAL
Joy of being together:
teamwork, tolerance and
sense of belonging



COGNITIVE
Joy of learning:
curiosity, understanding of causal
relationships and knowledge of the world



CREATIVE
Joy of creating:
co-creation and experimenting
with materials



BALANCE
To balance is to stay upright when walking or standing on a surface that makes this challenging (e.g. a wobbly, inclined, or narrow surface).



HANG IN ARMS
To hang in arms is the act of carrying the body with the hands or arms, possibly to traverse to another platform or play item.



SENSORY
To sense is the act of taking in information with the sensory system: seeing, feeling, hearing or sensing with the body.



BOUNCE
To bounce is the act of bouncing on a responsive, flexible, elastic or tensile surface.



JUMP
To jump is the act of jumping up or down on a hard surface.



SLIDE
To slide is the act of moving fast downwards seated on a slide.



CLIMB
To climb is the act of moving upwards, cross-coordinating arms and legs, on a vertical or inclined surface or net.



PULL
To pull is the act of pulling an item towards you or you towards an item with one or both hands, or possibly using the entire body.



SOCIALIZE
To socialize is the act of meeting, communicating or cooperating in an activity that stimulates and facilitates social interaction.



CONSTRUCT
To construct is the act of creating new patterns, shifting items or materials to new positions or constructing with materials that can be transformed or manipulated.



PUSH
To push is the act of pushing an item away from you with one or both hands, possibly with the entire body.



SPIN
To spin involves a fast, repeated horizontal or vertical turn of the body on a piece of equipment that facilitates the movement.



CRAWL
To crawl is the movement of moving forwards or backwards, cross-coordinating arms and legs, on a horizontal or slightly inclined surface.



ROCK
To rock is the action of rocking back and forth, or sideways, on e.g. a piece of spring equipment.



SWAY
To sway is the movement of swaying back and forth, or around, lying, seated or possibly standing, in a pendulant or circular movement, e.g. on a hammock or on a rope.



DRAMATIC PLAY
Dramatic play is motivated through play items that stage a frame, place or environment for acting out make believe or role play scenarios.



ROTATE
To rotate involves a vertical or horizontal slower paced turn of the body, facilitated by a piece of equipment.



SWING
To swing is the movement of swinging back and forth, or in circular movement, seated, standing or lying, in an unhindered arc.



GLIDE
To glide is the act of moving from one point to another without shifting the feet, in a horizontal or vertical movement, in a seated, lying or standing position, letting gravity do the work.



RULES PLAY
Rules play is motivated through play items that suggest games-with-rules, cooperation and team work, e.g. tic-tac-toe, timers or ball games.



WONDER
To wonder is motivated through play items that make children need and use their logical, abstract or creative thinking skills, as well as their memory.