

Komodo with shading

PCE211503

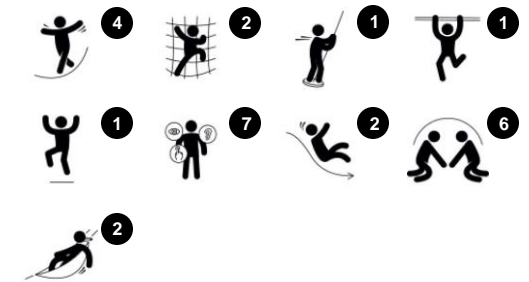

Item no. PCE211503-0902	
General Product Information	
Dimensions LxWxH	567x508x420 cm
Age group	3+
Play capacity (users)	14
Colour options	



The Komodo is a fantastic structure that attracts children. The variety of activities will encourage children to play longer and come back again and again. The Komodo offers ample climbing and balancing space for active children. The wobblybridge offers thrill for children who like to challenge themselves, and it provides a social opportunity to feel the

actions of others as children move across. The varied climbing units train proprioception and cross-body coordination, which are fundamental for children's reading skills. The curved slide and the fireman's pole are thrilling paths to return to the ground. As well as climbing and sliding, there are plenty of opportunities for social play that will help

children to build important social and emotional skills, and will motivate children to play for longer.

Komodo with shading

PCE211503

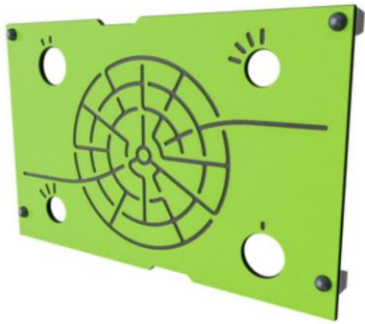

Panels of 19mm EcoCore™. EcoCore™ is a highly durable, eco friendly material, which is not only recyclable after use, but also consists of a core produced from 100% recycled material.



The ELEMENTS roofs are made of recyclable PE with a minimum wall thickness of 5mm to ensure high durability in all climates around the world. The steel pipes are hot dip galvanised inside and outside for maximum durability.



Sails of commercial 95 high density PE knitted specially for sun-shade structures. The sails are treated with UV stabilizers to ensure a long life-time. The sails are supported by a hot dip galvanised steel frame and tightened by stainless steel devices.

Item no. PCE211503-0902	
Installation Information	
Max. fall height	118 cm
Safety surfacing area	43.6 m ²
Numbers of installers (persons)	2
Total installation time	20.1
Excavation volume	0.99 m ³
Concrete volume	0.34 m ³
Footing depth (standard)	85 cm
Shipment weight	656 kg
Anchoring options	In-ground ✓
Warranty Information	
EcoCore HDPE	Lifetime
Post	10 years
HPL decks	10 years
Sun shading sails	2 years
Spare parts guaranteed	10 years



ELEMENTS decks are made of 17.8mm thick HPL supported by a unique designed aluminium frame with multiple attachment options by usage of aluminium connectors. The main posts are made of high quality pre-galvanised steel with powder coated top finish. Post tops are closed with caps of UV stabilised nylon (PA6).



The slides are available in either moulded PE in different colours or in full stainless steel AISI304 t= 2mm.



Steel activities are hot dip galvanised and optional with a powder coated top finish.



Komodo with shading

PCE211503

* Max fall height | ** Total height | *** Safety surfacing area

* Max fall height | ** Total height

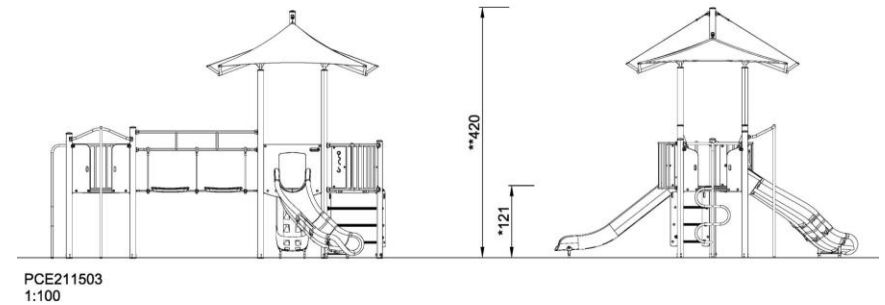
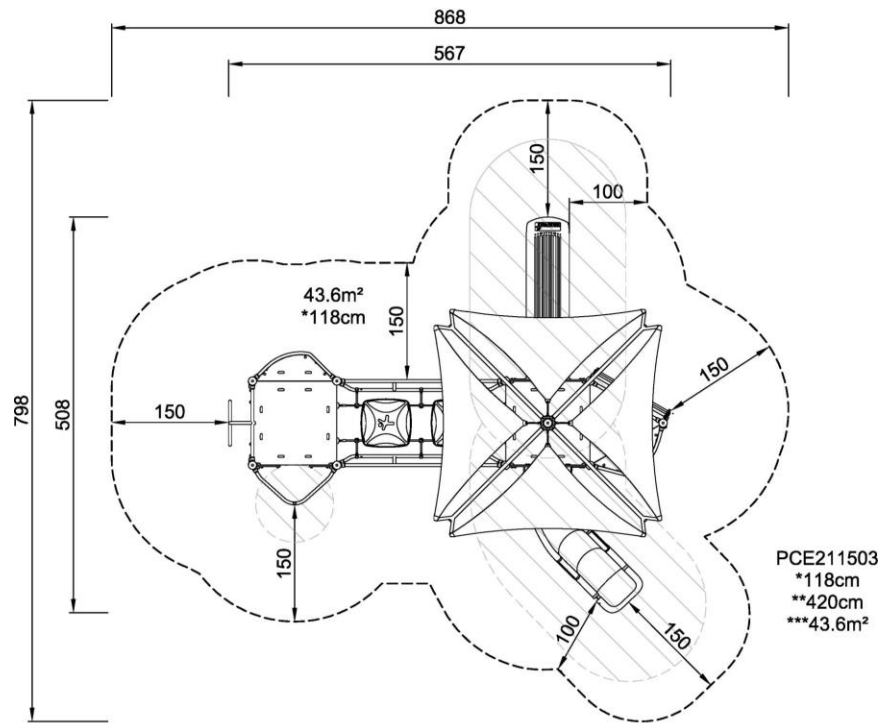

[Click to see 1:100 ratio TOP VIEW](#)

[Click to see 1:100 ratio SIDE VIEW](#)

Komodo with shading

PCE211503



Wackle bridge

Physical: sense of balance and space, and training of posture. Important for being able to sit still.
Social-Emotional: cooperation, turn-taking and friendly competition on the two plates.



Balcony

Social-Emotional: the balcony invites meetings and interaction with people on ground level.
Cognitive: invites dramatic play and performance, which stimulates language development.



Climbing pole

Physical: cross-coordination and muscle strength are trained.
Social-Emotional: turn-taking and cooperation.



Fireman's pole

Physical: coordination is supported when going down, as well as arm and core muscles. Landing strengthens bone density, which is built for life in childhood.
Social-Emotional: turn-taking and risk-taking.
Cognitive: young children develop their understanding of space, speed and distances when gliding down fast.



Curved slide

Physical: sliding develops spatial awareness and a sense of balance. Furthermore, the core muscles are trained when sitting upright going down.
Social-Emotional: empathy stimulated by turn-taking.
Cognitive: young children train their understanding of space, speed and distances when sliding down quickly.



Pipe ladder

Physical: cross-coordination and eye-hand coordination are supported when children climb the ladder. The climbing also supports leg and arm muscles.
Social-Emotional: social interaction when hanging out together, learning about turn taking and cooperation.



Komodo with shading

PCE211503



PHYSICAL
Joy of movement:
motor skills, muscle, cardio
and bone density



SOCIAL-EMOTIONAL
Joy of being together:
teamwork, tolerance and
sense of belonging



COGNITIVE
Joy of learning:
curiosity, understanding of causal
relationships and knowledge of the world



CREATIVE
Joy of creating:
co-creation and experimenting
with materials



BALANCE
To balance is to stay upright when walking or standing on a surface that makes this challenging (e.g. a wobbly, inclined, or narrow surface).



HANG IN ARMS
To hang in arms is the act of carrying the body with the hands or arms, possibly to traverse to another platform or play item.



SENSORY
To sense is the act of taking in information with the sensory system: seeing, feeling, hearing or sensing with the body.



BOUNCE
To bounce is the act of bouncing on a responsive, flexible, elastic or tensile surface.



JUMP
To jump is the act of jumping up or down on a hard surface.



SLIDE
To slide is the act of moving fast downwards seated on a slide.



CLIMB
To climb is the act of moving upwards, cross-coordinating arms and legs, on a vertical or inclined surface or net.



PULL
To pull is the act of pulling an item towards you or you towards an item with one or both hands, or possibly using the entire body.



SOCIALIZE
To socialize is the act of meeting, communicating or cooperating in an activity that stimulates and facilitates social interaction.



CONSTRUCT
To construct is the act of creating new patterns, shifting items or materials to new positions or constructing with materials that can be transformed or manipulated.



PUSH
To push is the act of pushing an item away from you with one or both hands, possibly with the entire body.



SPIN
To spin involves a fast, repeated horizontal or vertical turn of the body on a piece of equipment that facilitates the movement.



CRAWL
To crawl is the movement of moving forwards or backwards, cross-coordinating arms and legs, on a horizontal or slightly inclined surface.



ROCK
To rock is the action of rocking back and forth, or sideways, on e.g. a piece of spring equipment.



SWAY
To sway is the movement of swaying back and forth, or around, lying, seated or possibly standing, in a pendulant or circular movement, e.g. on a hammock or on a rope.



DRAMATIC PLAY
Dramatic play is motivated through play items that stage a frame, place or environment for acting out make believe or role play scenarios.



ROTATE
To rotate involves a vertical or horizontal slower paced turn of the body, facilitated by a piece of equipment.



SWING
To swing is the movement of swinging back and forth, or in circular movement, seated, standing or lying, in an unhindered arc.



GLIDE
To glide is the act of moving from one point to another without shifting the feet, in a horizontal or vertical movement, in a seated, lying or standing position, letting gravity do the work.



RULES PLAY
Rules play is motivated through play items that suggest games-with-rules, cooperation and team work, e.g. tic-tac-toe, timers or ball games.



WONDER
To wonder is motivated through play items that make children need and use their logical, abstract or creative thinking skills, as well as their memory.