

Tourmalet

PCE211301



Item no. PCE211301-0901

General Product Information

Dimensions LxWxH	718x428x260 cm
Age group	4+
Play capacity (users)	15
Colour options	

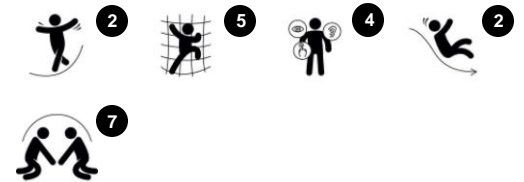

Wow! The Tourmalet is a fantastic accessible structure that attracts children from afar. The variety of activities will encourage children to play longer and come back again and again. The Tourmalet offers ample climbing and sliding for active children. The varied climbing units train proprioception and cross-body coordination, which are fundamental for

children's mathematical understanding. The slides are thrilling paths to get back down to the ground. Jacob's ladder offers climbing with a cognitive challenge, when children figure out how to move their bodies to reach the top. Apart from climbing and sliding, there are plenty of opportunities for social play that will help children to build important social and emotional

skills, and will motivate children to play for longer.



Data is subject to change without prior notice.

Tourmalet

PCE211301

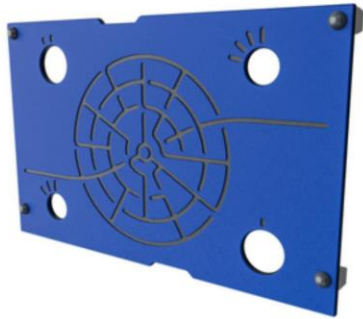

Panels of 19mm EcoCore™. EcoCore™ is a highly durable, eco friendly material, which is not only recyclable after use, but also consists of a core produced from 100% recycled material.



The ELEMENTS roofs are made of recyclable PE with a minimum wall thickness of 5mm to ensure high durability in all climates around the world. The steel pipes are hot dip galvanised inside and outside for maximum durability.



Sails of commercial 95 high density PE knitted specially for sun-shade structures. The sails are treated with UV stabilizers to ensure a long life-time. The sails are supported by a hot dip galvanised steel frame and tightened by stainless steel devices.

Item no. PCE211301-0901	
Installation Information	
Max. fall height	221 cm
Safety surfacing area	53.2 m ²
Numbers of installers (persons)	2
Total installation time	27.0
Excavation volume	0.59 m ³
Concrete volume	0.00 m ³
Footing depth (standard)	85 cm
Shipment weight	777 kg
Anchoring options	In-ground ✓
Warranty Information	
EcoCore HDPE	Lifetime
Post	10 years
HPL decks	10 years
Sun shading sails	2 years
Spare parts guaranteed	10 years



ELEMENTS decks are made of 17.8mm thick HPL supported by a unique designed aluminium frame with multiple attachment options by usage of aluminium connectors. The main posts are made of high quality pre-galvanised steel with powder coated top finish. Post tops are closed with caps of UV stabilised nylon (PA6).



The slides are available in either moulded PE in different colours or in full stainless steel AISI304 t= 2mm.



Steel activities are hot dip galvanised and optional with a powder coated top finish.



Tourmalet

PCE211301

* Max fall height | ** Total height | *** Safety surfacing area

* Max fall height | ** Total height

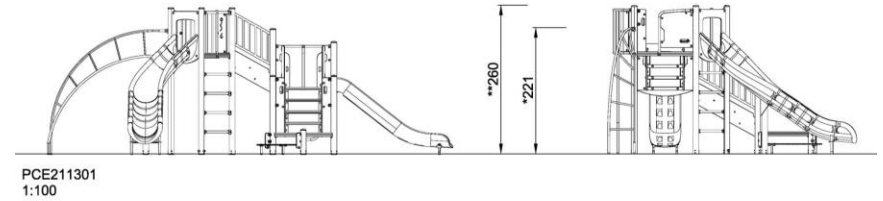
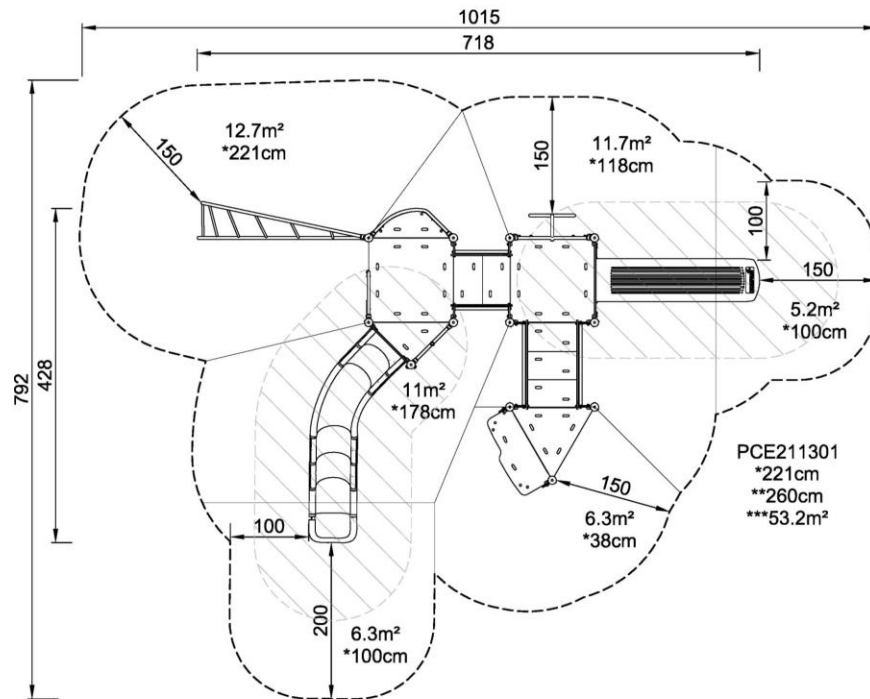

[Click to see 1:100 ratio TOP VIEW](#)

[Click to see 1:100 ratio SIDE VIEW](#)



Jacob's ladder

Physical: cross-coordination and spatial awareness as well as upper body muscles when hanging with arms. This is especially important due to sedentary lifestyles of today's children.

Social-Emotional: turn-taking and cooperation.

Cognitive: logical thinking when going from 2nd to 3rd step, changing feet.



Balcony

Social-Emotional: the balcony invites meetings and interaction with people on ground level.



Climbing pole

Physical: cross-coordination and muscle strength are trained.

Social-Emotional: turn-taking and cooperation.



Curved slide

Physical: sliding develops spatial awareness and a sense of balance. Furthermore, the core muscles are trained when sitting upright going down.

Social-Emotional: empathy stimulated by turn-taking.



Pipe ladder

Physical: cross-coordination and eye-hand coordination are supported when children climb the ladder. The climbing also supports leg and arm muscles.

Social-Emotional: social interaction when hanging out together, learning about turn taking and cooperation.



Accessible stairway

Physical: climbing the accessible stairway is for all and supports cross-coordination as well as arm and leg muscles. For young children, walking stairs and alternating feet is developed.

Social-Emotional: room for active breaks and adult helpers. An inclusive space.

Tourmalet

PCE211301



PHYSICAL

Joy of movement:
motor skills, muscle, cardio
and bone density



SOCIAL-EMOTIONAL

Joy of being together:
teamwork, tolerance and
sense of belonging



COGNITIVE

Joy of learning:
curiosity, understanding of causal
relationships and knowledge of the world



CREATIVE

Joy of creating:
co-creation and experimenting
with materials



BALANCE

To balance is to stay upright when walking or standing on a surface that makes this challenging (e.g. a wobbly, inclined, or narrow surface).



HANG IN ARMS

To hang in arms is the act of carrying the body with the hands or arms, possibly to traverse to another platform or play item.



SENSORY

To sense is the act of taking in information with the sensory system: seeing, feeling, hearing or sensing with the body.



BOUNCE

To bounce is the act of bouncing on a responsive, flexible, elastic or tensile surface.



JUMP

To jump is the act of jumping up or down on a hard surface.



SLIDE

To slide is the act of moving fast downwards seated on a slide.



CLIMB

To climb is the act of moving upwards, cross-coordinating arms and legs, on a vertical or inclined surface or net.



PULL

To pull is the act of pulling an item towards you or you towards an item with one or both hands, or possibly using the entire body.



SOCIALIZE

To socialize is the act of meeting, communicating or cooperating in an activity that stimulates and facilitates social interaction.



CONSTRUCT

To construct is the act of creating new patterns, shifting items or materials to new positions or constructing with materials that can be transformed or manipulated.



PUSH

To push is the act of pushing an item away from you with one or both hands, possibly with the entire body.



SPIN

To spin involves a fast, repeated horizontal or vertical turn of the body on a piece of equipment that facilitates the movement.



CRAWL

To crawl is the movement of moving forwards or backwards, cross-coordinating arms and legs, on a horizontal or slightly inclined surface.



ROCK

To rock is the action of rocking back and forth, or sideways, on e.g. a piece of spring equipment.



SWAY

To sway is the movement of swaying back and forth, or around, lying, seated or possibly standing, in a pendulant or circular movement, e.g. on a hammock or on a rope.



DRAMATIC PLAY

Dramatic play is motivated through play items that stage a frame, place or environment for acting out make believe or role play scenarios.



ROTATE

To rotate involves a vertical or horizontal slower paced turn of the body, facilitated by a piece of equipment.



SWING

To swing is the movement of swinging back and forth, or in circular movement, seated, standing or lying, in an unhindered arc.



GLIDE

To glide is the act of moving from one point to another without shifting the feet, in a horizontal or vertical movement, in a seated, lying or standing position, letting gravity do the work.



RULES PLAY

Rules play is motivated through play items that suggest games-with-rules, cooperation and team work, e.g. tic-tac-toe, timers or ball games.



WONDER

To wonder is motivated through play items that make children need and use their logical, abstract or creative thinking skills, as well as their memory.