

SHIP LARGE - WOOD POSTS

KPL520

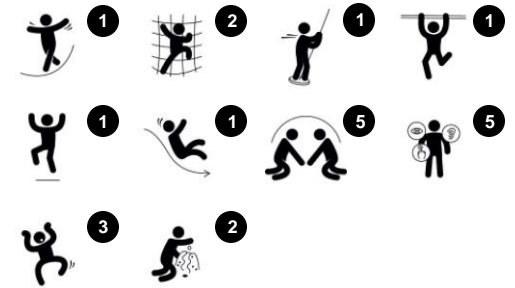

Item no. KPL520-0901	
General Product Information	
Dimensions LxWxH	417 x 440 x 362 cm
Age Group	3+
Play Capacity	15 children
Colour Options	



The KOMPAN Pirate Ship inspires and attracts play again and again. The strong theme inspires dramatic play, and the variation of climbing, gliding and sliding attracts play on end, again and again, year after year. The unit forms a whole playground with its diverse play activities. The open space behind the keel features a steering wheel. This spurs dramatic

play conversations, stimulating language and communication skills. The cabin under deck has a nice seat for socializing. A climbing wall and access climber lead to the deck. Up here there is another steering wheel, supporting dramatic play and turn-taking skills. From upper deck, the child can slide, or take a whizzing glide down the dare-devil fireman's pole. This trains

the understanding of space and helps the child build up and understanding of space and measures.

SHIP LARGE - WOOD POSTS

KPL520

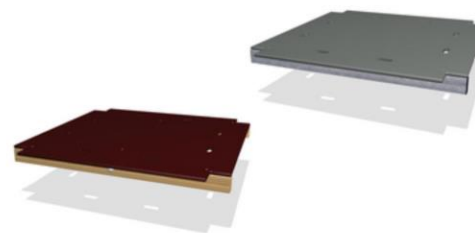
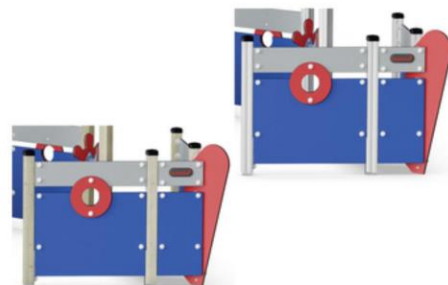

Panels of 19mm EcoCore™. EcoCore™ is a highly durable, eco friendly material, which is not only recyclable after use, but also consists of a core produced from 100% recycled material.

Posts are available in two types of material: Pine wood posts pressure impregnated class AB with tanalith E3475 according to EN335 or aluminium post t=2mm with anodized surface treatment. Base material EN AW 6060 T66.

Floors and panel activities are available in two types of material: Waterproof plywood decks thickness 21,5mm from pine and alder wood with anti-slip film on both sides. High Pressure Laminate HPL thickness 17,8mm with nonskid surface texture according to EN 438-6.

Item no. KPL520-0901	
Installation Information	
Max. fall height	148 cm
Safety surfacing area	36.8 m ²
Numbers of Installers (persons)	2
Total installation time	19
Excavation volume	1.33 m ³
Concrete volume	0.38 m ³
Footing Depth (Standard)	90 cm
Shipment Weight	613 kg
Anchoring options	In-ground ✓ Surface ✓
Warranty information	
Panels	Lifetime
Post	10 Years
Floors (decks)	10 Years
Ropes	5 Years
Spare parts guaranteed	10 Years

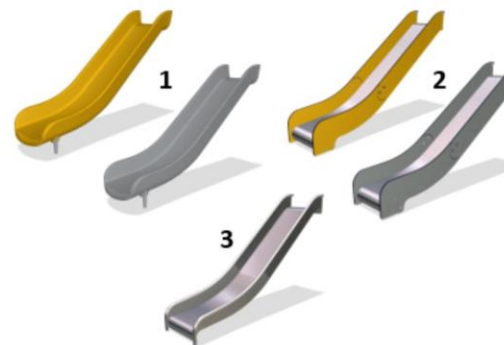

The main posts are equipped with hot dip galvanised steel footings. The steel footings elevates the posts 20mm from ground level to avoid contact with surfacing material.

Steel components are hot dip galvanised inside and outside with lead free zinc. The galvanisation has excellent corrosion resistance in outside environments and requires low maintenance.

Slides are available in three different materials: moulded on piece PE slides, Combined EcoCore™ sides and stainless steel slide bed t=2mm. Full stainless steel AISI304 t=2mm.



SHIP LARGE - WOOD POSTS

KPL520

Max fall height | Total height | Safety surfacing area

Max fall height | Total height

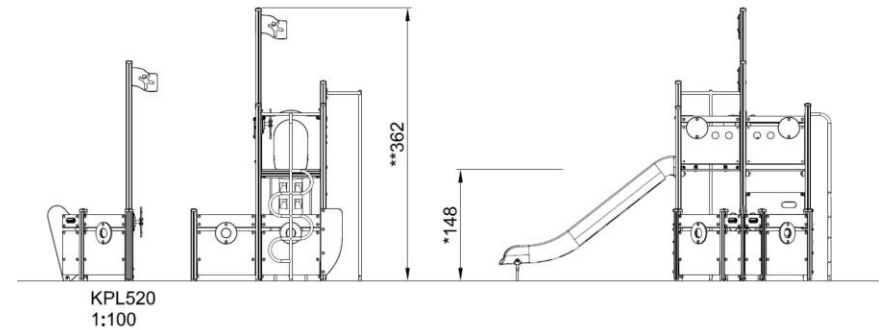
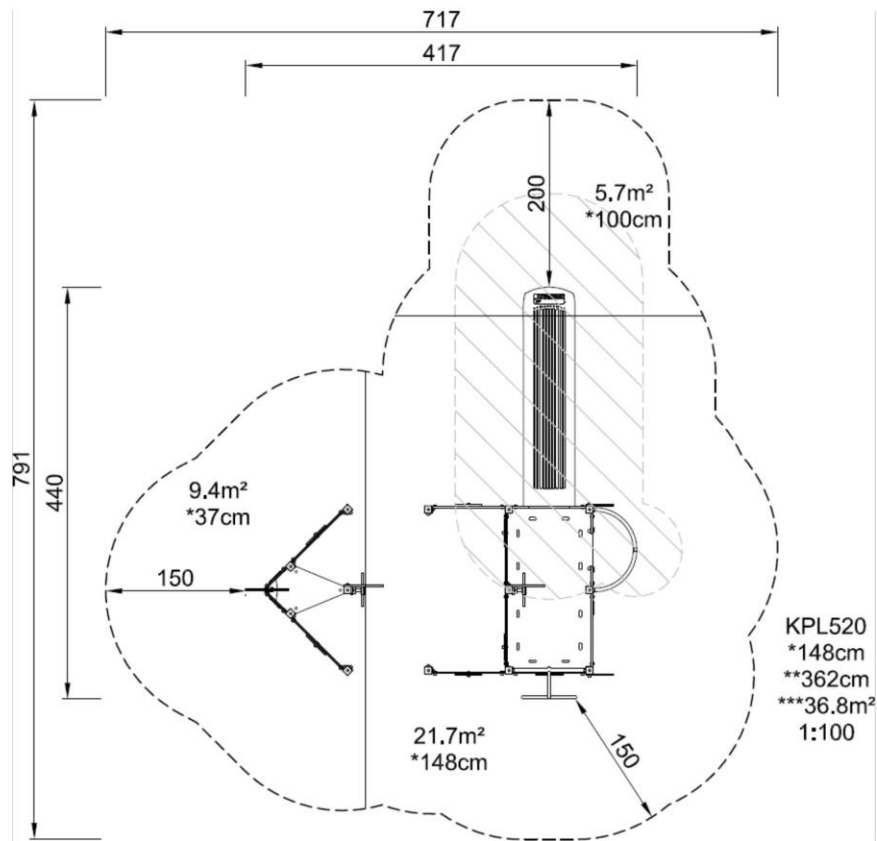

[Click to see 1:100 ratio TOP VIEW](#)

[Click to see 1:100 ratio SIDE VIEW](#)

SHIP LARGE - WOOD POSTS

KPL520



Steering wheel

Cognitive: the manipulative steering wheel stimulates cause and effect understanding. It invites dramatic play which supports language and communication skills.



Ship

Cognitive: suggests a theme and supports dramatic play, which stimulates languages and communication skills.



Fireman's pole

Physical: balance and coordination are supported when going down, as well as arm and core muscles. Jumping off strengthens bone density, which is built for life in early childhood.
Social-Emotional: turn-taking and risk-taking.
Cognitive: young children develop their understanding of space, speed and distances when sliding down fast.



Climbing pole

Physical: coordination, muscle strength.
Social-Emotional: turn-taking and cooperation.
Cognitive: logical thinking when climbing up.



Slide

Physical: sliding develops spatial awareness and sense of balance. Furthermore, the core muscles are trained when sitting upright going down.
Social-Emotional: empathy stimulated by turn-taking.
Cognitive: young children develop their understanding of space, speed and distances when sliding down fast.



Climbing wall

Physical: develops children's cross coordination, eye-hand coordination, and muscle strength when climbing.
Social-Emotional: two-sided climb invites cooperation.



Open space in front

Social-Emotional: the bench along the keel is a great space for meeting and exchanging.

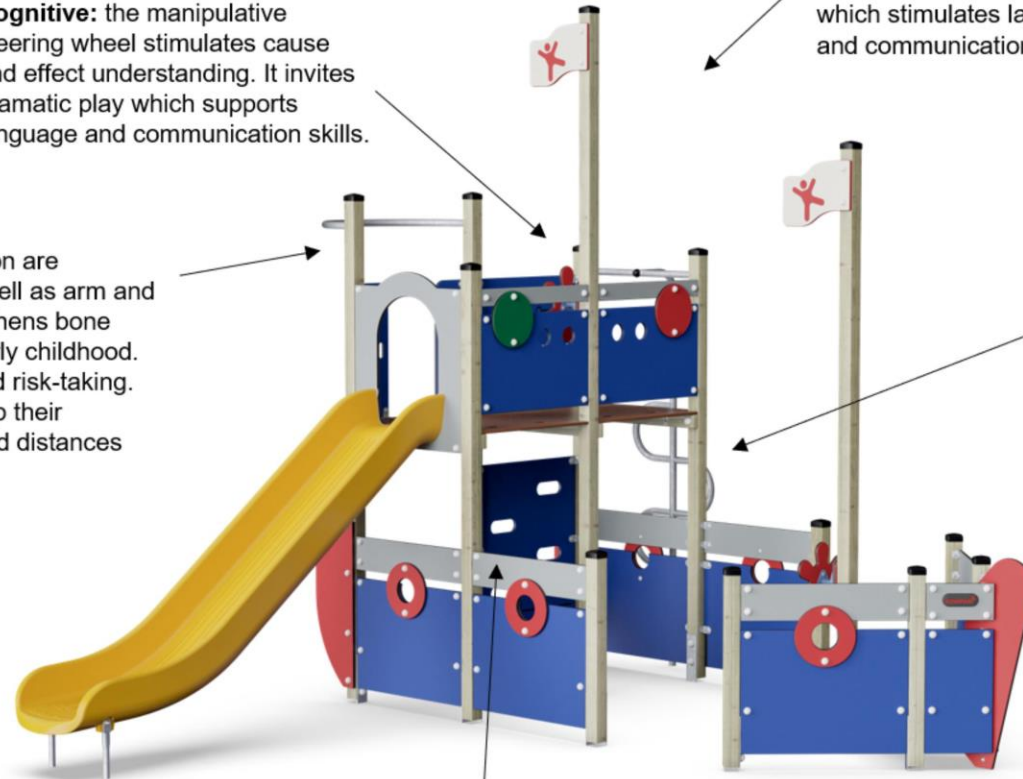

SHIP LARGE - WOOD POSTS

KPL520



PHYSICAL
Joy of movement:
motor skills, muscle, cardio
and bone density



SOCIAL-EMOTIONAL
Joy of being together:
teamwork, tolerance and
sense of belonging



COGNITIVE
Joy of learning:
curiosity, understanding of causal
relationships and knowledge of the world



CREATIVE
Joy of creating:
co-creation and experimenting
with materials



BALANCE
To balance is to stay upright when walking or standing on a surface that makes this challenging (e.g. a wobbly, inclined, or narrow surface).



HANG IN ARMS
To hang in arms is the act of carrying the body with the hands or arms, possibly to traverse to another platform or play item.



SENSORY
To sense is the act of taking in information with the sensory system: seeing, feeling, hearing or sensing with the body.



BOUNCE
To bounce is the act of bouncing on a responsive, flexible, elastic or tensile surface.



JUMP
To jump is the act of jumping up or down on a hard surface.



SLIDE
To slide is the act of moving fast downwards seated on a slide.



CLIMB
To climb is the act of moving upwards, cross-coordinating arms and legs, on a vertical or inclined surface or net.



PULL
To pull is the act of pulling an item towards you or you towards an item with one or both hands, or possibly using the entire body.



SOCIALIZE
To socialize is the act of meeting, communicating or cooperating in an activity that stimulates and facilitates social interaction.



CONSTRUCT
To construct is the act of creating new patterns, shifting items or materials to new positions or constructing with materials that can be transformed or manipulated.



PUSH
To push is the act of pushing an item away from you with one or both hands, possibly with the entire body.



SPIN
To spin involves a fast, repeated horizontal or vertical turn of the body on a piece of equipment that facilitates the movement.



CRAWL
To crawl is the movement of moving forwards or backwards, cross-coordinating arms and legs, on a horizontal or slightly inclined surface.



ROCK
To rock is the action of rocking back and forth, or sideways, on e.g. a piece of spring equipment.



SWAY
To sway is the movement of swaying back and forth, or around, lying, seated or possibly standing, in a pendulant or circular movement, e.g. on a hammock or on a rope.



DRAMATIC PLAY
Dramatic play is motivated through play items that stage a frame, place or environment for acting out make believe or role play scenarios.



ROTATE
To rotate involves a vertical or horizontal slower paced turn of the body, facilitated by a piece of equipment.



SWING
To swing is the movement of swinging back and forth, or in circular movement, seated, standing or lying, in an unhindered arc.



GLIDE
To glide is the act of moving from one point to another without shifting the feet, in a horizontal or vertical movement, in a seated, lying or standing position, letting gravity do the work.



RULES PLAY
Rules play is motivated through play items that suggest games-with-rules, cooperation and team work, e.g. tic-tac-toe, timers or ball games.



WONDER
To wonder is motivated through play items that make children need and use their logical, abstract or creative thinking skills, as well as their memory.