

# CROSSED LADDER

COR15062

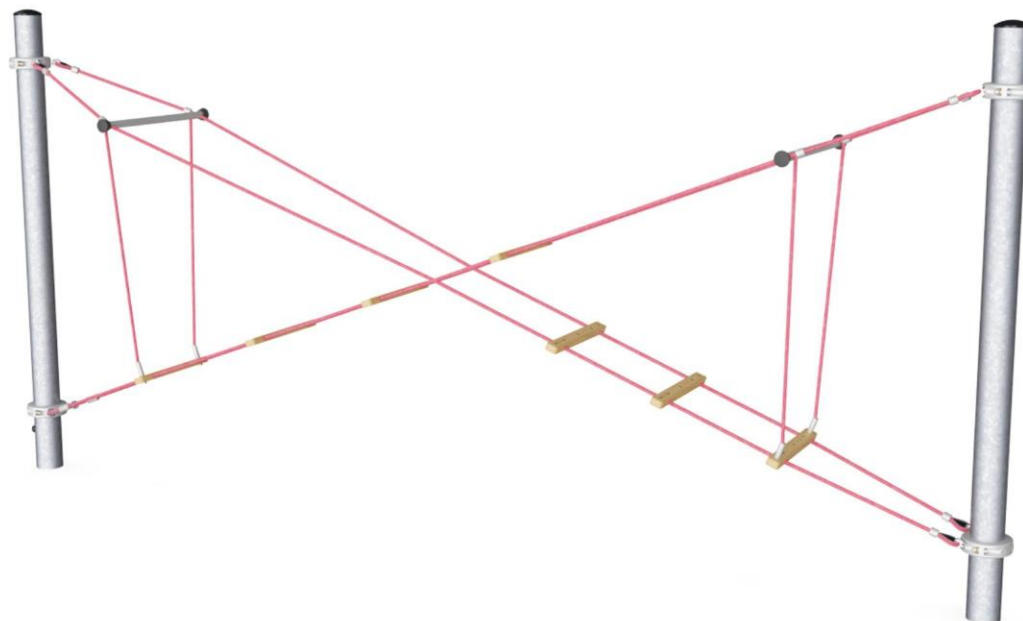

Item no. COR150620-1101	
General Product Information	
Dimensions LxWxH	625 x 97 x 290 cm
Age Group	5+
Play Capacity	10 children
Colour Options	

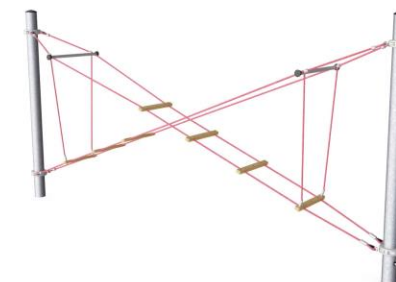
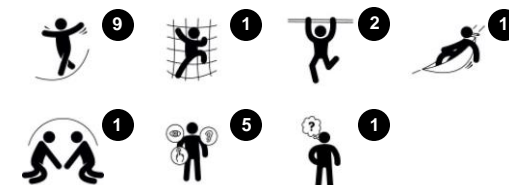

The Crossed Ladder is an intriguing invitation to play for older children. The swaying movements and the combination of open, asymmetric steps and metal bars makes climbing the Crossed Ladder exciting and thrilling. The Crossed Ladder bounces back the child's movements, adding an element of concentration to passing. This trains the sense of balance, which is

fundamental for the child's confidence in moving securely. A good sense of balance is additionally a fundament for cognitive skills such as concentration. The Crossed Ladder also trains important social skills such as turn taking and consideration when children pass each other on the steps. The steel bars function as break points for this. They additionally invite

seated, bouncy breaks for friends to meet and exchange.

# CROSSED LADDER

COR15062



Corocord ropes with 19 mm diameter or more are special „Hercules“ – type with galvanised six-stranded steel wires. Each strand is tightly wrapped with PES yarn, which is melted onto each individual strand. The ropes are highly wear-and vandalism-resistant and can be replaced at site if needed.



The steel posts are hot dip galvanised inside and outside with lead free zinc. The galvanisation has excellent corrosion resistance in outside environments and requires low maintenance.



Corocord aluminum clamps are used as connectors between steel posts and rope. Two aluminum castings are bolted together. The height of the clamps is thus variable.



For this product, you have got the choice between 8 rope colours. The assortment is a wide span of colours ranking from elegant and expressive black or natural and toned-down hemp colour, to a range of attractive and eye-catching signal colours.

Item no. COR150620-1101	
Installation Information	
Max. fall height	265 cm
Safety surfacing area	48.6 m <sup>2</sup>
Numbers of Installers (persons)	2
Total installation time	5
Excavation volume	4.31 m <sup>3</sup>
Concrete volume	2.74 m <sup>3</sup>
Footing Depth (Standard)	110 cm
Shipment Weight	318 kg
Anchoring options	In-ground ✓
Warranty information	
Corocord Rope	5 Years
S-Clamps	10 Years
Membrane	2 Years
Spare parts guaranteed	10 Years



# CROSSED LADDER

COR15062

Max fall height | Total height | Safety surfacing area

Max fall height | Total height

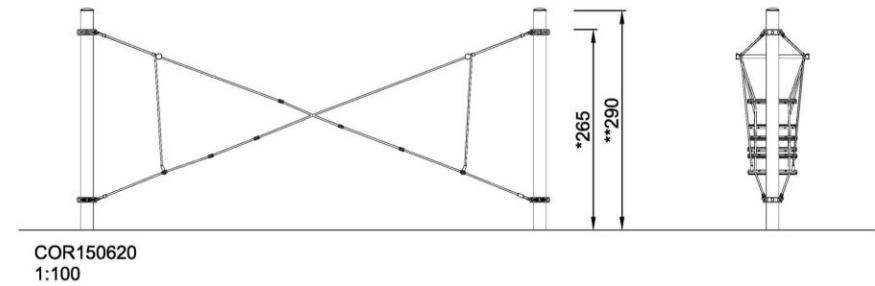
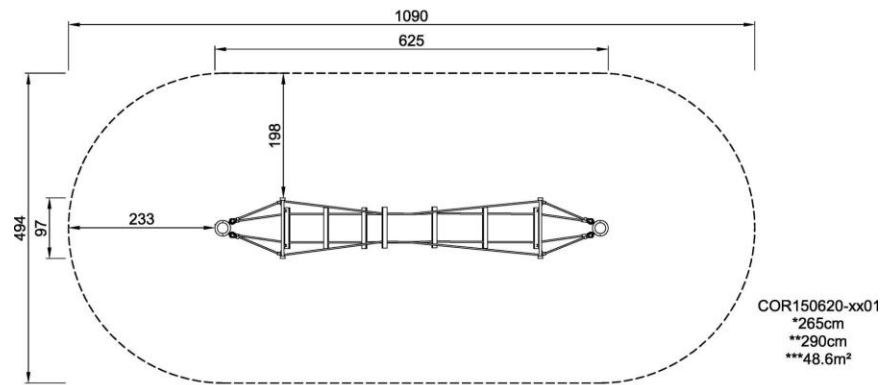

[Click to see 1:100 ratio TOP VIEW](#)

[Click to see 1:100 ratio SIDE VIEW](#)

# CROSSED LADDER

COR15062



## Crossed ladder

**Physical:** all muscles are used to hold tight when crossing the swaying ladders. Additionally, they stimulate balance, coordination and spatial awareness. These support the ability to navigate securely in crowded spaces. Children also develop timing as they move their body across the space.

**Social-Emotional:** passing others on the bridge stimulates cooperation and positive exchange.

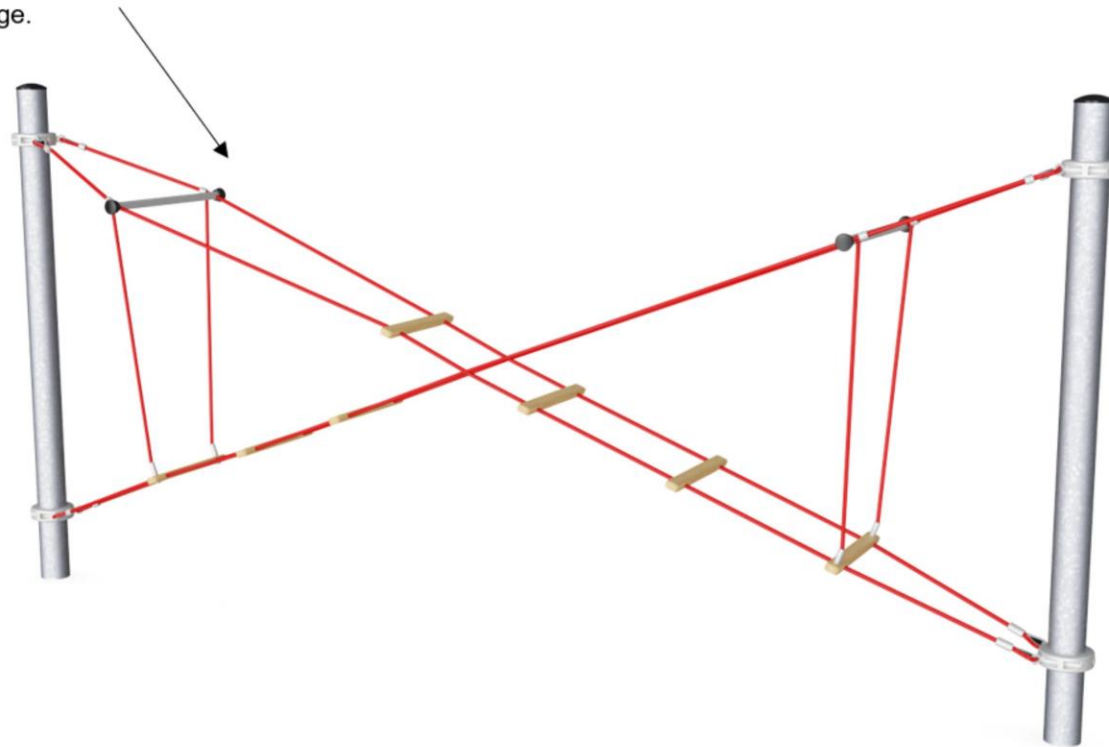

# CROSSED LADDER

COR15062



**PHYSICAL**  
Joy of movement:  
motor skills, muscle, cardio  
and bone density



**SOCIAL-EMOTIONAL**  
Joy of being together:  
teamwork, tolerance and  
sense of belonging



**COGNITIVE**  
Joy of learning:  
curiosity, understanding of causal  
relationships and knowledge of the world



**CREATIVE**  
Joy of creating:  
co-creation and experimenting  
with materials



**BALANCE**  
To balance is to stay upright when walking or standing on a surface that makes this challenging (e.g. a wobbly, inclined, or narrow surface).



**HANG IN ARMS**  
To hang in arms is the act of carrying the body with the hands or arms, possibly to traverse to another platform or play item.



**SENSORY**  
To sense is the act of taking in information with the sensory system: seeing, feeling, hearing or sensing with the body.



**BOUNCE**  
To bounce is the act of bouncing on a responsive, flexible, elastic or tensile surface.



**JUMP**  
To jump is the act of jumping up or down on a hard surface.



**SLIDE**  
To slide is the act of moving fast downwards seated on a slide.



**CLIMB**  
To climb is the act of moving upwards, cross-coordinating arms and legs, on a vertical or inclined surface or net.



**PULL**  
To pull is the act of pulling an item towards you or you towards an item with one or both hands, or possibly using the entire body.



**SOCIALIZE**  
To socialize is the act of meeting, communicating or cooperating in an activity that stimulates and facilitates social interaction.



**CONSTRUCT**  
To construct is the act of creating new patterns, shifting items or materials to new positions or constructing with materials that can be transformed or manipulated.



**PUSH**  
To push is the act of pushing an item away from you with one or both hands, possibly with the entire body.



**SPIN**  
To spin involves a fast, repeated horizontal or vertical turn of the body on a piece of equipment that facilitates the movement.



**CRAWL**  
To crawl is the movement of moving forwards or backwards, cross-coordinating arms and legs, on a horizontal or slightly inclined surface.



**ROCK**  
To rock is the action of rocking back and forth, or sideways, on e.g. a piece of spring equipment.



**SWAY**  
To sway is the movement of swaying back and forth, or around, lying, seated or possibly standing, in a pendulant or circular movement, e.g. on a hammock or on a rope.



**DRAMATIC PLAY**  
Dramatic play is motivated through play items that stage a frame, place or environment for acting out make believe or role play scenarios.



**ROTATE**  
To rotate involves a vertical or horizontal slower paced turn of the body, facilitated by a piece of equipment.



**SWING**  
To swing is the movement of swinging back and forth, or in circular movement, seated, standing or lying, in an unhindered arc.



**GLIDE**  
To glide is the act of moving from one point to another without shifting the feet, in a horizontal or vertical movement, in a seated, lying or standing position, letting gravity do the work.



**RULES PLAY**  
Rules play is motivated through play items that suggest games-with-rules, cooperation and teamwork, e.g. tic-tac-toe, timers or ball games.



**WONDER**  
To wonder is motivated through play items that make children need and use their logical, abstract or creative thinking skills, as well as their memory.