

# CROSS TRAINER



FAZ52100

**KOMPAN**  
Let's play



Item no. FAZ52100-0801

## General Product Information

Dimensions LxWxH	179 x 83 x 175 cm
Age Group	13+
Capacity	1 adult
Colour Options	 



The popular cross-trainer known from indoor fitness is now available for outdoor training. With the best ergonomics on the market, KOMPAN's Cross Trainer gives an intense workout and adds an extra intensity layer with a special sprint mode (glute mode) that allows a high-calorie workout that strengthens the gluteus and lower limbs while focusing on the

core stabilizer muscles. The KOMPAN Cross Trainer provides a safe, non-impacting workout without putting unnecessary stress on the joints. The KOMPAN cardio family is designed to give users of all ages, physiques and fitness levels a cardiovascular training that keeps their heart rate above the needed 65% of their maximum heart rate. The intelligent system

automatically adapts the workout to the pace set by the user, securing that the user gets a proper resistance. Besides the automatic drive the user can also choose to manually adjust the resistance with the KOMPAN cardio APP.



# CROSS TRAINER

FAZ52100



When working out, motivation is key. Users can connect via Bluetooth to the KOMPAN Cardio app and get access to instructional and motivational videos, store activity and share to external platforms



The cross trainer has one welded steel frame connecting the front and the back of the machine. The frame creates an extremely strong and rigid construction which is needed to cope with the high forces that can be applied.



The cover is made of one of the hardest materials in the market, a Lexan Copolymer EXL9330 and has a thickness of 4mm. This cover can withstand any impact and will protect the electronics in the best possible way.

Item no. FAZ52100-0801	
Installation Information	
Max. fall height	60 cm
Safety surfacing area	15.3 m <sup>2</sup>
Numbers of Installers (persons)	2
Total installation time	4
Excavation volume	0.68 m <sup>3</sup>
Concrete volume	0.42 m <sup>3</sup>
Footing Depth (Standard)	80 cm
Shipment Weight	286 kg
Anchoring options	In-ground ✓ Surface ✓
Warranty information	
Footrests	10 Years
Frame	10 Years
Handlebars	10 Years
Electronics	2 Years
Spare parts guaranteed	10 Years



The innovative self-powered electrical motor and gear providing a virtual flywheel to give a real road cycle experience. The resistance works as an automatic drive and adapts automatically. The users can overwrite the automatic drive manually by changing the resistance in 10 steps (45 – 750 Watts) through the app or screen.



The handlebars are designed with multiple hand positions to accommodate different postures and riding styles. It is a casted aluminum part with a polyurea coating for good grip and insulation.



The footrests are made 39 cm long x 15 cm wide, accommodating all foot sizes. The back of the footrest has a specifically designed inclined surface which will bring the users into a sprint position, using much more of the gluteus, hamstrings and lower back muscles.



# CROSS TRAINER

FAZ52100

Max fall height | Total height | Safety surfacing area

Max fall height | Total height

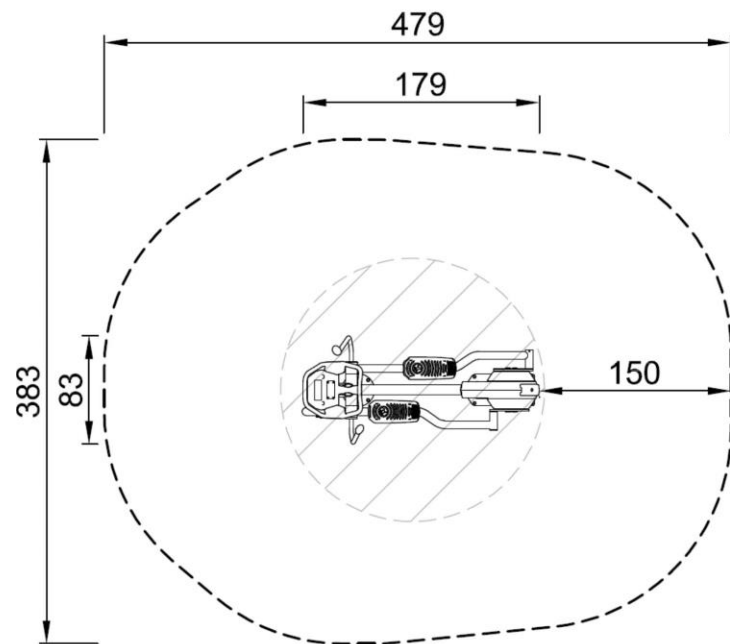

FAZ521  
\*60cm  
\*\*175cm  
\*\*\*15.3m<sup>2</sup>

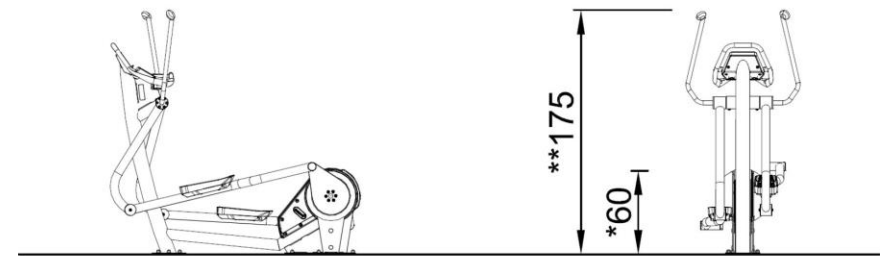

FAZ521  
1:100

[Click to see 1:100 ratio TOP VIEW](#)

[Click to see 1:100 ratio SIDE VIEW](#)