

Sand Creator

PCM507



Item no. PCM507-0902

General Product Information

Dimensions LxWxH	350x243x217 cm
Age group	2+
Play capacity (users)	20
Colour options	

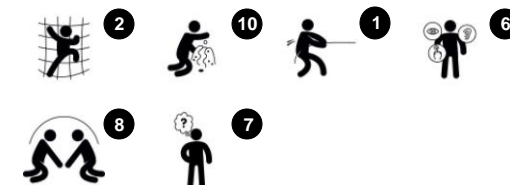

The Sand Creator is an immensely attractive sand play unit that will absorb children in play for hours and hours. The crane is worked by pulling the chain. The sand bucket will go up or down or all around, but it will stay put when the chain is let go of. This, apart from providing fascinating sand play, is a great training of children's logical thinking skills. The negotiation

and cooperation to get sand to and from the funnel via the bucket is great for older children and develops social-emotional skills. In the house, multiple tactile elements can be moved to entertain children who wait for the sand crane. The sand funnel here supports children's understanding of object permanence: that things can still exist when out of sight. The

platform is open and can be accessed in multiple ways, allowing for all users to play.

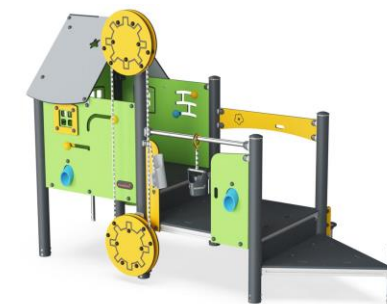

Data is subject to change without prior notice.

Sand Creator

PCM507



Panels of 19mm EcoCore™. EcoCore™ is a highly durable, eco friendly material, which is not only recyclable after use, but also consists of a core produced from 100% recycled material.



All decks are supported by unique designed aluminium profiles with multiple attachment options by usage of pressure moulded aluminium connectors. The HPL decks with a thickness of 17.8 mm with a very high wearing strength and a unique KOMPAN non skid surface texture.



Sand shovel is made of PP and attached to the stainless steel pipe by a stainless steel chain. PP has good wearing and impact resistance.



The sand hoist is designed with upper and lower EcoCore tracks of large diameter that always ensures safe distance between the chains so they can't be crossed for entanglement. The chain is made of high-quality stainless-steel to ensure long durability of the product.



The sand bucket is made in one piece of molded PE. PE has high impact resistance across a wide temperature span which ensures vandal resistance in all locations.



Sand pipe is made of PP. PP has good wearing and impact resistance which makes it perfect for sand play activities.

Item no. PCM507-0902

Installation Information

Max. fall height	68 cm
Safety surfacing area	26,2 m ²
Number of installers	2
Total installation time	14.3
Excavation volume	0,30 m ³
Concrete volume	0,01 m ³
Footing depth (standard)	90 cm
Shipment weight	420 kg
Anchoring options	In-ground ✓ Surface ✓

Warranty Information

EcoCore HDPE	Lifetime
HPL decks	15 years
Post	10 years
Solid plastic parts	10 years
Spare parts guaranteed	10 years



Sand Creator

PCM507

* Max fall height | ** Total height | *** Safety surfacing area

* Max fall height | ** Total height

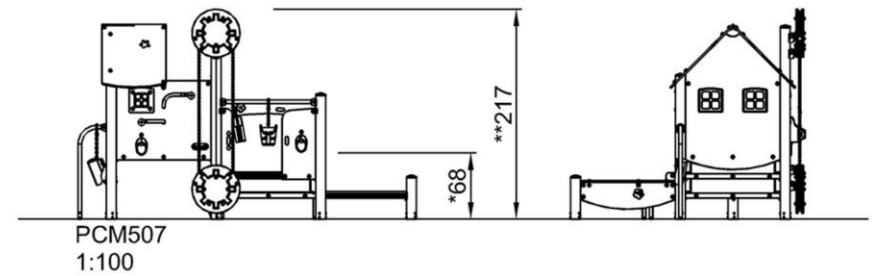
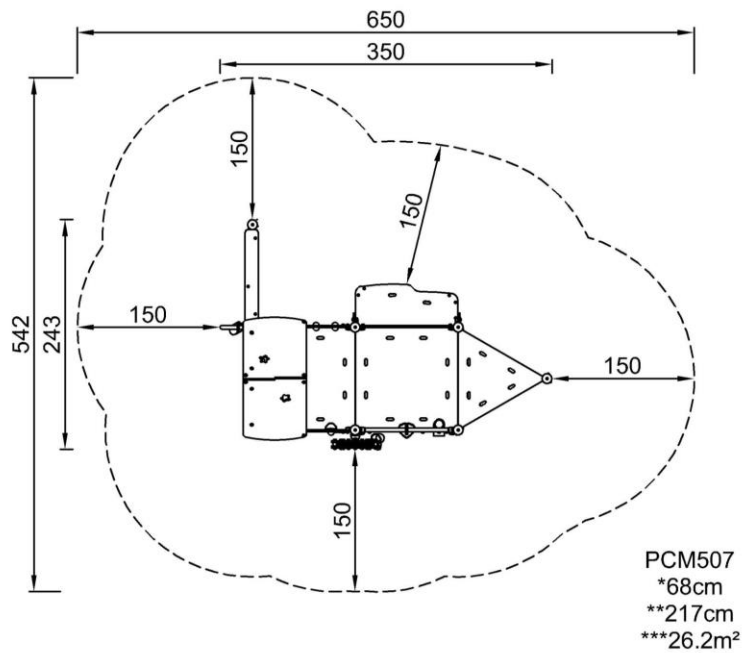

[Click to see 1:100 ratio TOP VIEW](#)

[Click to see 1:100 ratio SIDE VIEW](#)

Sand Creator

PCM507



Desk

Social-Emotional: fine meeting place and a space creator. Sharing and cooperation from both sides create a social scenario that supports communication and cooperation.



Sand shovel

Physical: develops dexterity and upper body muscles.
Cognitive: understanding of object permanence, emptying and filling scoop.



Sand scoops

Physical: hand eye coordination and push-pull movements.
Social-Emotional: invites cooperation due to the two-sidedness and provides for parallel play.
Cognitive: logical thinking: cause and effect understanding when running scoops in grooves or shifting materials from scoop to scoop.
Creative: shifting scoops, creating new scoop positions.



Play spheres

Social-Emotional: can be played from both sides, encouraging cooperation.
Cognitive: cause and effect understanding.
Creative: leave a mark and place the spheres at different positions.



Sand bucket on tube

Physical: filling and emptying the sand bucket trains fine motor skills as well as hand strength.
Social-Emotional: cooperating with others on the ground on filling and emptying the bucket supports negotiation and turn-taking skills.
Cognitive: helps to develop cause-and-effect understanding of younger children when buckets are transported on tubes, filled and emptied.



Funnel

Social-Emotional: trains cooperation and turn-taking as children put materials into the funnel.
Cognitive: the passing of materials through funnels supports the children's logical thinking and for younger children the understanding of object permanence: that materials don't vanish but run through at the other end.



Sand hoist

Physical: pulling the chain trains hand and arm muscles as well as the coordination of movements.
Social-Emotional: cooperation and turn-taking skills are supported when cooperating from platform to ground level on filling and hoisting sand up and down.
Cognitive: logical thinking skills are trained when understanding that pulling down makes the sand shovel go up.
Creative: working with movable play items that can leave a mark supports the child's creativity.

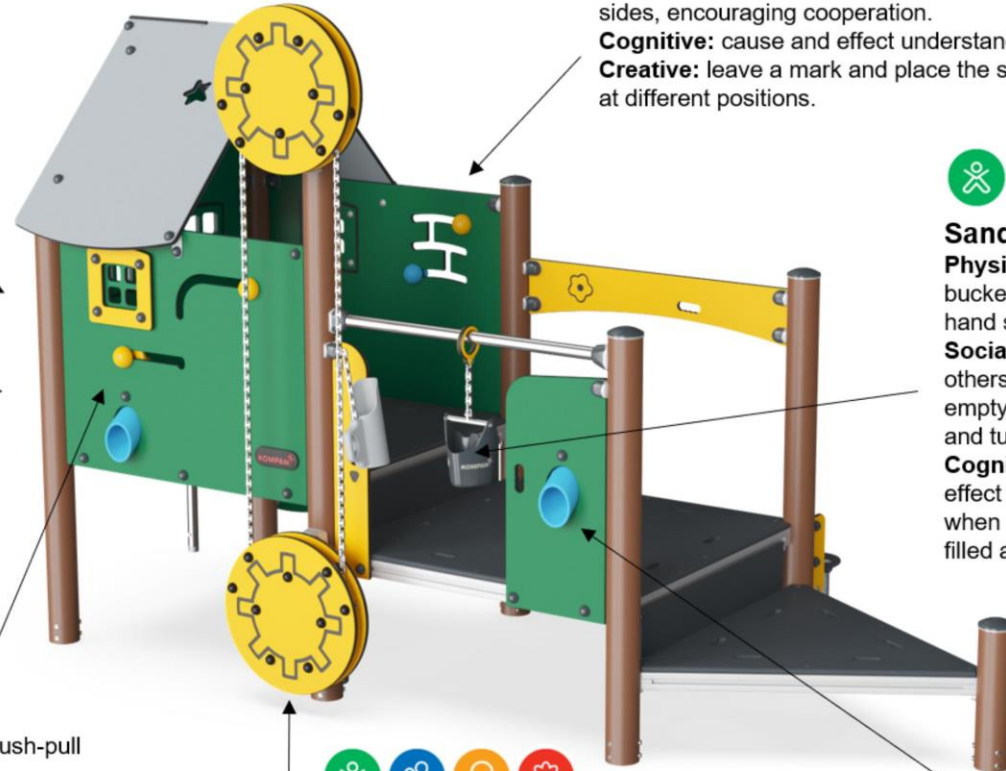

Sand Creator

PCM507



PHYSICAL

Joy of movement:
motor skills, muscle, cardio
and bone density



SOCIAL-EMOTIONAL

Joy of being together:
teamwork, tolerance and
sense of belonging



COGNITIVE

Joy of learning:
curiosity, understanding of causal
relationships and knowledge of the world



CREATIVE

Joy of creating:
co-creation and experimenting
with materials



BALANCE

To balance is to stay upright when walking or standing on a surface that makes this challenging (e.g. a wobbly, inclined, or narrow surface).



HANG IN ARMS

To hang in arms is the act of carrying the body with the hands or arms, possibly to traverse to another platform or play item.



SENSORY

To sense is the act of taking in information with the sensory system: seeing, feeling, hearing or sensing with the body.



BOUNCE

To bounce is the act of bouncing on a responsive, flexible, elastic or tensile surface.



JUMP

To jump is the act of jumping up or down on a hard surface.



SLIDE

To slide is the act of moving fast downwards seated on a slide.



CLIMB

To climb is the act of moving upwards, cross-coordinating arms and legs, on a vertical or inclined surface or net.



PULL

To pull is the act of pulling an item towards you or you towards an item with one or both hands, or possibly using the entire body.



SOCIALIZE

To socialize is the act of meeting, communicating or cooperating in an activity that stimulates and facilitates social interaction.



CONSTRUCT

To construct is the act of creating new patterns, shifting items or materials to new positions or constructing with materials that can be transformed or manipulated.



PUSH

To push is the act of pushing an item away from you with one or both hands, possibly with the entire body.



SPIN

To spin involves a fast, repeated horizontal or vertical turn of the body on a piece of equipment that facilitates the movement.



CRAWL

To crawl is the movement of moving forwards or backwards, cross-coordinating arms and legs, on a horizontal or slightly inclined surface.



ROCK

To rock is the action of rocking back and forth, or sideways, on e.g. a piece of spring equipment.



SWAY

To sway is the movement of swaying back and forth, or around, lying, seated or possibly standing, in a pendulant or circular movement, e.g. on a hammock or on a rope.



DRAMATIC PLAY

Dramatic play is motivated through play items that stage a frame, place or environment for acting out make believe or role play scenarios.



ROTATE

To rotate involves a vertical or horizontal slower paced turn of the body, facilitated by a piece of equipment.



SWING

To swing is the movement of swinging back and forth, or in circular movement, seated, standing or lying, in an unhindered arc.



GLIDE

To glide is the act of moving from one point to another without shifting the feet, in a horizontal or vertical movement, in a seated, lying or standing position, letting gravity do the work.



RULES PLAY

Rules play is motivated through play items that suggest games-with-rules, cooperation and team work, e.g. tic-tac-toe, timers or ball games.



WONDER

To wonder is motivated through play items that make children need and use their logical, abstract or creative thinking skills, as well as their memory.