

Little Fox' Shop

NRO418

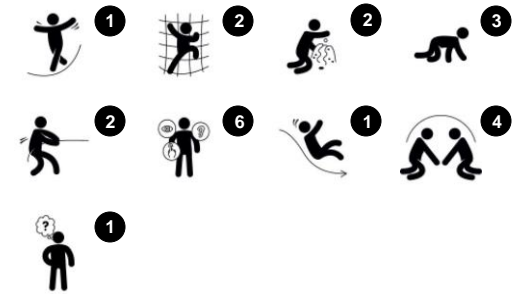

Item no. NRO418-1021	
General Product Information	
Dimensions LxWxH	284x420x218 cm
Age group	1+
Play capacity (users)	18
Colour options	



The Little Fox' Shop has meandering, low floors and a dense, activity packed climb and slide offering with an elevated play house that will attract and excite toddlers again and again. Rich tactile features greatly increase playvalue and support emerging dramatic play in the toddlers. The scale of the Little Fox' Shop is perfectly shaped for toddlers. The leafy crawl-through panel encourages children to crawl and explore.. The window with curtain invites social

cooperation between inside and outside, supporting turn-taking and cooperation skills and not least inviting peek-a-boo games that support the understanding of object permanence: that things don't cease to exist when they are out of sight. These tactile activities stimulate cross-modal perception, important for improving reading skills and support cross-coordination awareness which is key to physical and cognitive development at

this age. The house with its many details and corners supports emerging dramatic play which stimulates language skills. Thrilling sliding is invited with a friendly loop between access platform and slide mouth. The inclined climbing wall on the other side adds varied access and supports cross-coordination which is key to physical as well as cognitive development at this age.



Little Fox' Shop

NRO418



All Organic Robinia products by KOMPAN are made of 100% Robinia wood from sustainable European sources. On request it can be supplied with FSC® Certified (FSC® C004450) Robinia wood.



The product/activities are preassembled from the factory to ensure all safety requirements are considered.



The paint used for coloured components is water based environmental friendly with excellent UV resistance. The paint is in compliance with EN 71 Part 3.

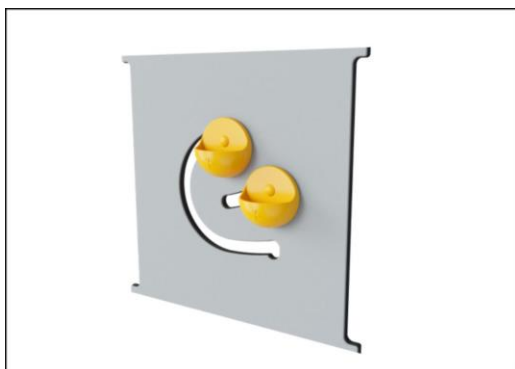

Panels of 19mm EcoCore™. EcoCore™ is a highly durable, eco friendly material, which is not only recyclable after use, but also consists of a core produced from 100% recycled material.



There are Multiple footing options for all products: Surface anchoring with steel footings and expansion bolts. Wood in-ground or steel in-ground footings.



Robinia products are available in three different wood treatment options: untreated Robinia wood or brown painted with a pigment that maintains the wood colour and coloured version with paint of selected components.

Item no. NRO418-1021

Installation Information

Max. fall height	100 cm
Safety surfacing area	29,2 m ²
Number of installers	2
Total installation time	24.1
Excavation volume	1,75 m ³
Concrete volume	0,00 m ³
Footing depth (standard)	100 cm
Shipment weight	930 kg
Anchoring options	In-ground ✓ Surface ✓

Warranty Information

Robinia wood	15 years
Stainless steel components	Lifetime
Hot dip galvanised steel	Lifetime
EcoCore HDPE	Lifetime
Spare parts guaranteed	10 years



* Max fall height | ** Total height | *** Safety surfacing area

* Max fall height | ** Total height

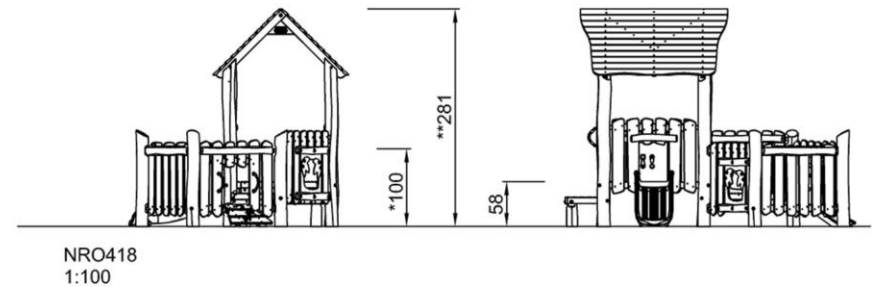
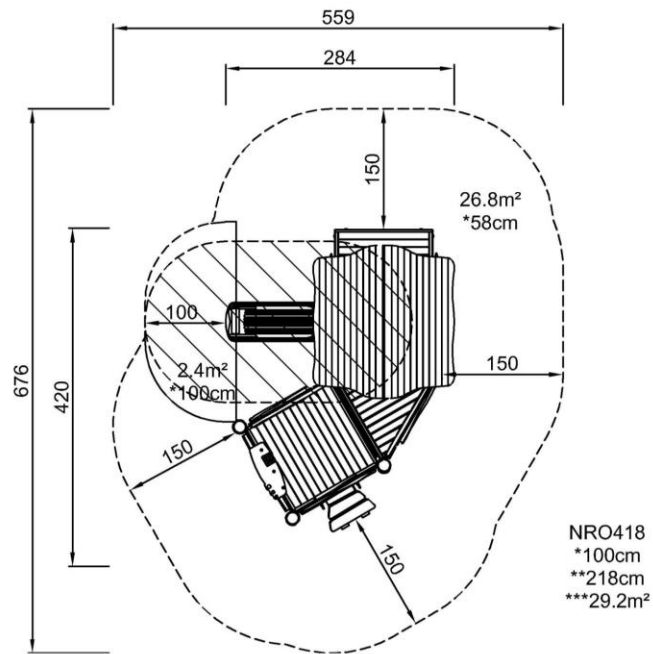

[Click to see 1:100 ratio TOP VIEW](#)

[Click to see 1:100 ratio SIDE VIEW](#)

Little Fox' Shop

NRO418



Gear wheels

Social-Emotional: cooperation skills and turn-taking are supported when turning the gearing wheel.

Cognitive: cause and effect understanding, and logical thinking are supported.



Supportive handholds

Physical: handhold provides good grip for less confident climbers. Pulling yourself up and in trains upper body muscles.

Social-Emotional: allows for a range of physical abilities to enter independently and securely, supporting play for all.



Slide

Physical: sliding develops spatial awareness and a sense of balance. Furthermore, the core muscles are trained when sitting upright going down.

Social-Emotional: empathy stimulated by turn-taking.

Cognitive: young children develop their understanding of space, speed and distances when sliding down quickly.

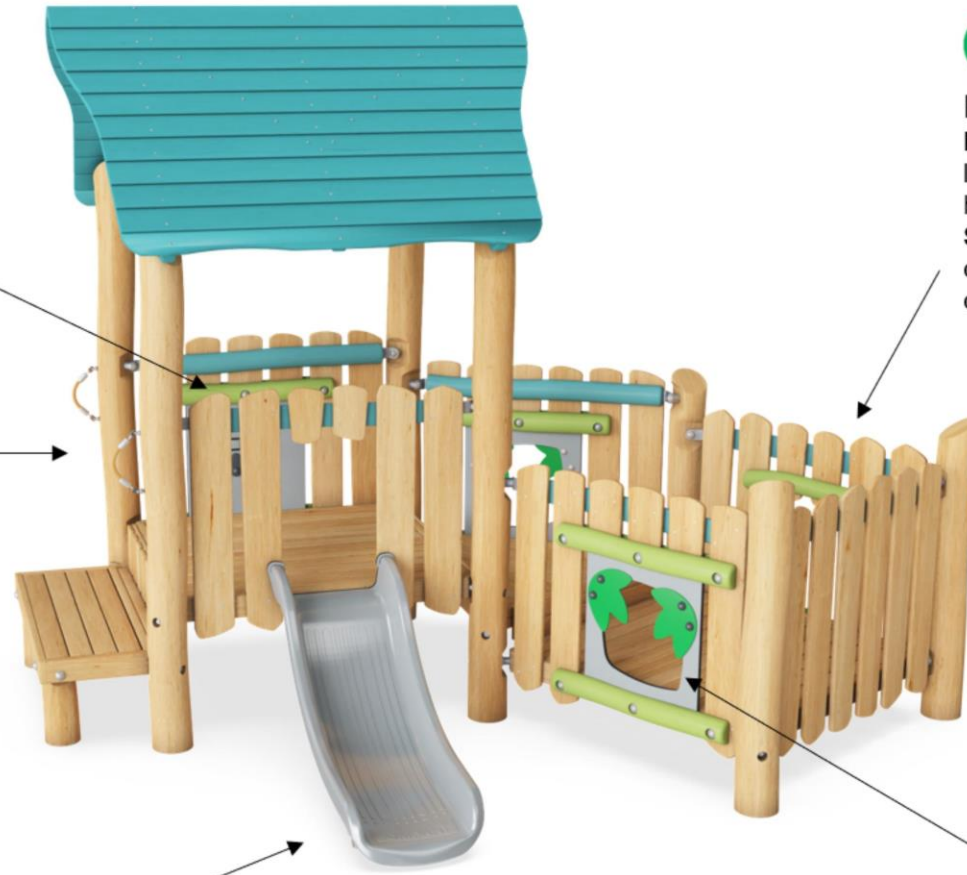

Rock climber

Physical: supports cross coordination and leg, arm and hand strength. The handholds on top ease entry into platform.

Social-Emotional: the inclination makes climbing feel secure, especially for younger children.



Crawl-through hole

Physical: the hole allows for climbing and crawling through, developing cross coordination, proprioception and spatial awareness.

Social-Emotional: cooperation and turn-taking when passing one another.

Cognitive: understanding space, shape and measures when seeing if the body can fit through the hole.



PHYSICAL
Joy of movement:
motor skills, muscle, cardio
and bone density



SOCIAL-EMOTIONAL
Joy of being together:
teamwork, tolerance and
sense of belonging



COGNITIVE
Joy of learning:
curiosity, understanding of causal
relationships and knowledge of the world



CREATIVE
Joy of creating:
co-creation and experimenting
with materials



BALANCE
To balance is to stay upright when walking or standing on a surface that makes this challenging (e.g. a wobbly, inclined, or narrow surface).



HANG IN ARMS
To hang in arms is the act of carrying the body with the hands or arms, possibly to traverse to another platform or play item.



SENSORY
To sense is the act of taking in information with the sensory system: seeing, feeling, hearing or sensing with the body.



BOUNCE
To bounce is the act of bouncing on a responsive, flexible, elastic or tensile surface.



JUMP
To jump is the act of jumping up or down on a hard surface.



SLIDE
To slide is the act of moving fast downwards seated on a slide.



CLIMB
To climb is the act of moving upwards, cross-coordinating arms and legs, on a vertical or inclined surface or net.



PULL
To pull is the act of pulling an item towards you or you towards an item with one or both hands, or possibly using the entire body.



SOCIALIZE
To socialize is the act of meeting, communicating or cooperating in an activity that stimulates and facilitates social interaction.



CONSTRUCT
To construct is the act of creating new patterns, shifting items or materials to new positions or constructing with materials that can be transformed or manipulated.



PUSH
To push is the act of pushing an item away from you with one or both hands, possibly with the entire body.



SPIN
To spin involves a fast, repeated horizontal or vertical turn of the body on a piece of equipment that facilitates the movement.



CRAWL
To crawl is the movement of moving forwards or backwards, cross-coordinating arms and legs, on a horizontal or slightly inclined surface.



ROCK
To rock is the action of rocking back and forth, or sideways, on e.g. a piece of spring equipment.



SWAY
To sway is the movement of swaying back and forth, or around, lying, seated or possibly standing, in a pendulant or circular movement, e.g. on a hammock or on a rope.



DRAMATIC PLAY
Dramatic play is motivated through play items that stage a frame, place or environment for acting out make believe or role play scenarios.



ROTATE
To rotate involves a vertical or horizontal slower paced turn of the body, facilitated by a piece of equipment.



SWING
To swing is the movement of swinging back and forth, or in circular movement, seated, standing or lying, in an unhindered arc.



GLIDE
To glide is the act of moving from one point to another without shifting the feet, in a horizontal or vertical movement, in a seated, lying or standing position, letting gravity do the work.



RULES PLAY
Rules play is motivated through play items that suggest games-with-rules, cooperation and team work, e.g. tic-tac-toe, timers or ball games.



WONDER
To wonder is motivated through play items that make children need and use their logical, abstract or creative thinking skills, as well as their memory.