

Gogetter

PCE205321



| Item no. PCE205321-0902 | |
|-----------------------------|---|
| General Product Information | |
| Dimensions LxWxH | 605x333x418 cm |
| Age group | 2+ |
| Play capacity (users) | 19 |
| Colour options | ● ● ● |



The Gogetter is a fantastic structure with loads of play opportunities that will encourage children to stay and play, and return again and again. These play experiences will support children's development in all areas. The slide supports physical skills such as balance and spatial awareness. The climbing net supports strength and cross-coordination, important

skills for physical as well as intellectual development. There is more than one way to climb, which supports play for children who seek variety and challenge. With so many play activities, social experiences are also supported, especially with such features as the flower panel, where children can play and cooperate. The flower panel adds a tactile

feature that stimulates cause-and-effect understanding. The Gogetter is perfect for active and fun play.

Gogetter

PCE205321

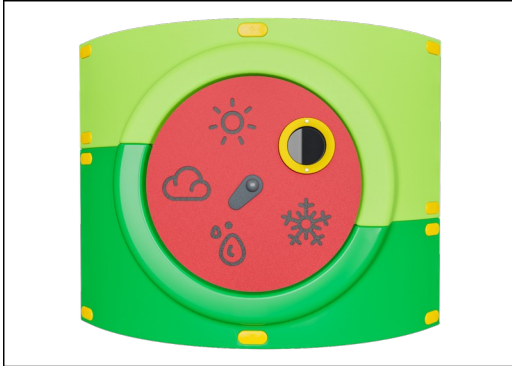

The Curved ELEMENTS panels are moulded of UV stabilised recyclable PE with multiple options for in-build play features that also ensures a strong panel solution. Straight panels are made of KOMPAN 19mm PE EcoCore™ which is a highly durable, ecofriendly and recyclable material.

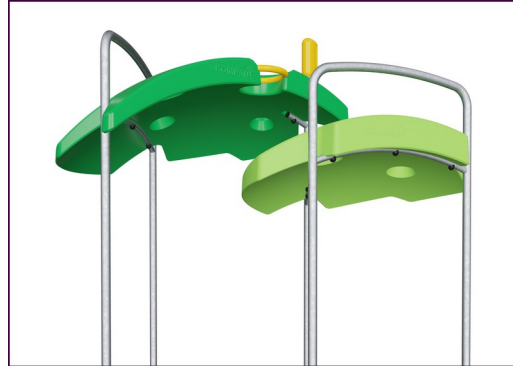

The ELEMENTS roofs are made of recyclable PE with a minimum wall thickness of 5 mm to ensure high durability in all climates around the world. The steel pipes are hot dip galvanised inside and outside for maximum durability.



ELEMENTS products are available in three different colour combinations: classic blue & green, blossom orange & yellow, nature lime and green.



The main posts are made of high quality pre-galvanized steel with powder coated top finish. Post tops are closed with caps of UV stabilized nylon (PA6). The grey colored molded decks are made of 75% post-consumer ocean waste PP material with a non-skid pattern and texture surface. All decks are supported by unique designed low-carbon aluminum profiles with multiple attachment options.

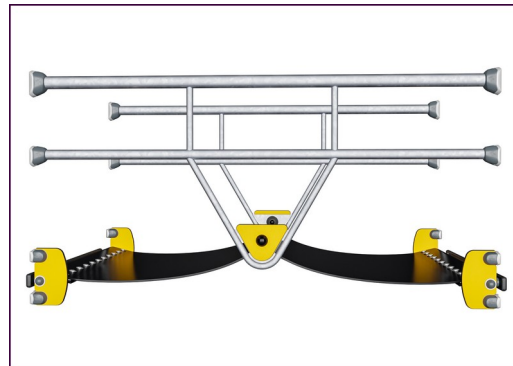

ELEMENTS rubber membranes are conveyor belt made of layers of rubber mixed of natural rubber and SBR rubber, and embedded with layers of armouring made of woven PE and PA. The thickness 8mm ensures high durability in any environment.

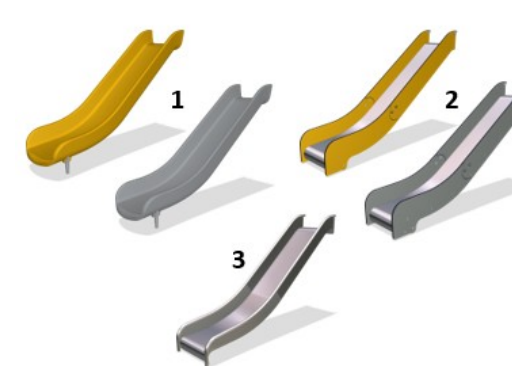

The slides are available in either moulded PE in different colours or in full stainless steel AISI304 t= 2mm.

Item no. PCE205321-0902

Installation Information

| | |
|--------------------------|--------------------------|
| Max. fall height | 176 cm |
| Safety surfacing area | 38.8 m ² |
| Number of installers | 2 |
| Total installation time | 19.6 |
| Excavation volume | 1.11 m ³ |
| Concrete volume | 0.29 m ³ |
| Footing depth (standard) | 90 cm |
| Shipment weight | 641 kg |
| Anchoring options | Surface ✓ In-ground ✓ |

Warranty Information

| | |
|------------------------|----------|
| EcoCore HDPE | Lifetime |
| Post | 10 years |
| PP Decks | 10 years |
| Ropes & nets | 10 years |
| Spare parts guaranteed | 10 years |





| Cradle to Gate A1-A3 | Total CO ₂ emission | CO ₂ e/kg | Recycled materials |
|-----------------------|--------------------------------|-------------------------|--------------------|
| | kg CO ₂ e | kg CO ₂ e/kg | % |
| PCE205321-0902 | 1,418.90 | 2.89 | 41.00 |

The overall framework applied for these factors is the Environmental Product Declaration (EPD), which quantifies "environmental information on the life cycle of a product and enable comparisons between products fulfilling the same function" (ISO, 2006). This follows the structure and applies a Life-Cycle Assessment approach to the entire Product stage from raw material through manufacturing (A1-A3))

Kompan A/S
 C.F. Tietgens Boulevard 32C
 DK-5220 Odense SØ
 Denmark



Validation of CO₂ calculation of: Play systems



Data version no. 2021-01-11

The CO₂ calculation and data are in compliance with the principles of a carbon footprint impact according to the GHG protocol (Greenhouse Gas Protocol), Scope 3, cradle to gate related to all individual components in the product category: "Play systems" represented by item no.: PCM200309-0010. (Scope 3 emissions include emission sources in the upstream and downstream value chain).

Date: 15. October 2021 | Valid until: 15. October 2023

Validated by:

Bente Hviid, Senior Consultant

Peter Bendtsen, Senior Consultant

Validation based on report: Validation of CO₂ calculation of play systems – Kompan, version 1.0, prepared by: Bureau Veritas HSE, Denmark: Bente Hviid and Peter Bendtsen.

Publication date: 15. October 2021

By Bureau Veritas HSE
 www.bureauveritas.dk
 +45 7731 1000



* Max fall height | ** Total height | *** Safety surfacing area

* Max fall height | ** Total height

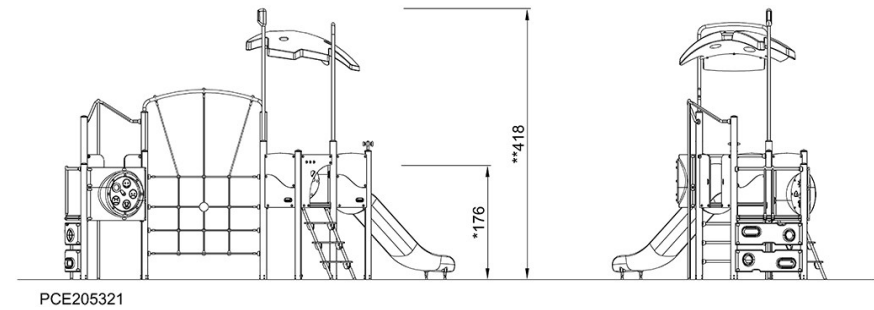
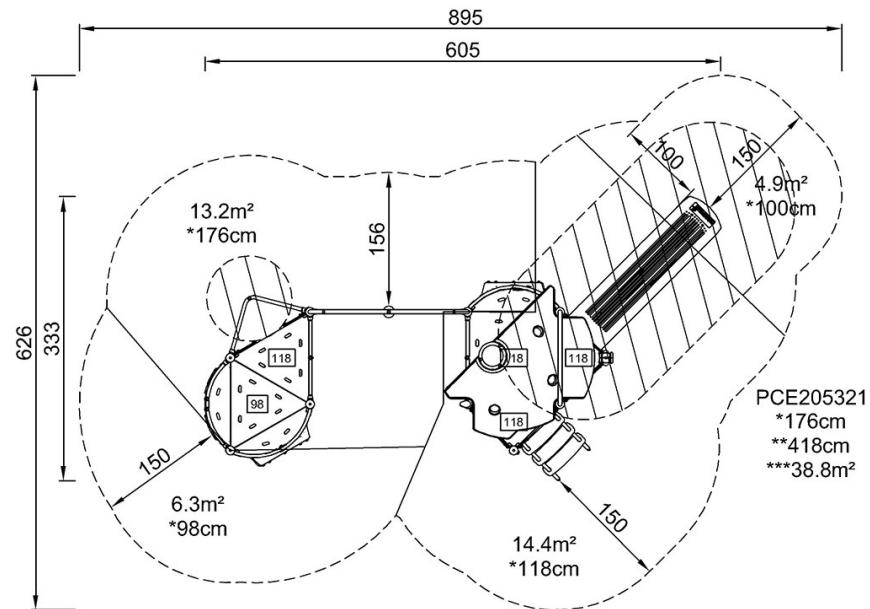

[Click to see TOP VIEW](#)

[Click to see SIDE VIEW](#)