

Organizzazione certificata Q.C.B. Italia ISO 9001:2015

 ORGANIZATION WITH ENVIRONMENTAL MANAGEMENT SYSTEM
 ISO 14001:2015 CERTIFIED by
 EuCI European Certification Institute LTD
 Certificate No: GOTT2532E1801

504 JIMBO STORY



SLIDING



CLIMBING



CATALOG COLLECTION	CLASSIC COLLECTION
DIMENSIONS (L x W x H) in cm	500 x 530 x 340
MAXIMUM CFH	100
IMPACT ATTENUATING SURFACE	min. 52,75 m ² - MAX 72,25 m ²
SUGGESTED AGE OF USE	3 - 12

COMPOSITION

- n°6 timber or aluminium poles 9x9cm
- n°2 timber or aluminium decks
- n°1 pyramid roof in rotational PTE
- n°2 metal guardpanels
- n°2 rotating mold PTE guardpanels
- n°1 rotating mold PTE climbing
- n°1 double slide with HDPE crossbar
- n°1 modular slide with HDPE crossbar
- n°1 climbing with ladder

SECURITY AREA

830

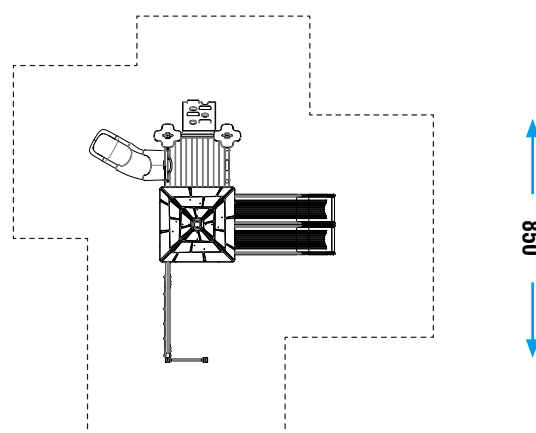

Make a proper security surface according to CFH. **Periodic maintenance is mandatory**, following manual supplied to customer.