

PRODUCT SHEET  
REV 1.0 - EN202003  
**4503 ANUK**



ORGANIZATION WITH QUALITY MANAGEMENT SYSTEM  
ISO 9001:2015 CERTIFIED by  
EuCI European Certification Institute LTD  
Certificate N.: GOTT253201932

ORGANIZATION WITH ENVIRONMENTAL MANAGEMENT SYSTEM  
ISO 14001:2015 CERTIFIED by  
EuCI European Certification Institute LTD  
Certificate N.: GOTT2532E1904



<b>DIMENSIONS (L x W x H) in cm</b>	525 x 550 x 355
<b>MAXIMUM CFH</b>	160
<b>IMPACT ATTENUATING SURFACE</b>	min. 70,25 m <sup>2</sup> - MAX 80,75 m <sup>2</sup>
<b>SUGGESTED AGE OF USE</b>	3 +

- COMPOSITION**
- n°11 octagonal profile aluminium structural poles
  - n°4 powder coated aluminium treadplate decks
  - n°4 metal guardpanels
  - n°2 rotating mold PTE guardpanels
  - n°1 aluminium stair
  - n°1 slabs bridge
  - n°1 rope net bridge
  - n°1 HDPE sheet climbing
  - n°1 HDPE sheet playpanel
  - n°2 rotating mold PTE modular slides
  - n°1 rotating mold PTE modular spiryal slide
  - n°4 HDPE sheet decorations

**PLAY AREA**

815

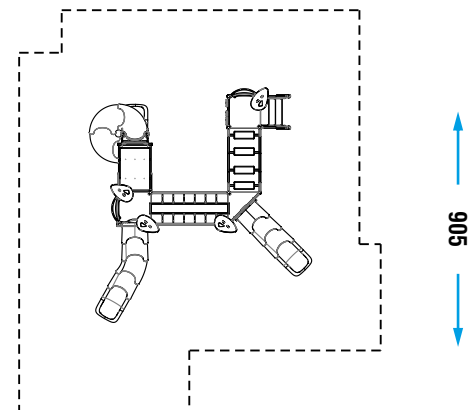

Make a proper security surface according to CFH. Periodic maintenance is mandatory, following manual supplied to customer.