

Organizzazione certificata Q.C.B. Italia ISO 9001:2015

ORGANIZATION WITH ENVIRONMENTAL MANAGEMENT SYSTEM
ISO 14001:2015 CERTIFIED by
EuCI European Certification Institute LTD
Certificate No: GOTT2532E1801

555 CANAL GRANDE

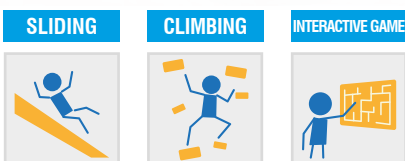

CATALOG COLLECTION	CLASSIC COLLECTION
DIMENSIONS (L x W x H) in cm	520 x 580 x 320
MAXIMUM CFH	125
IMPACT ATTENUATING SURFACE	min. 54,50 m ² - MAX 68,00 m ²
SUGGESTED AGE OF USE	3 - 12

COMPOSITION	<ul style="list-style-type: none"> - n°10 timber or aluminium poles 9x9cm - n°3 timber or aluminium decks - n°1 pyramid roof - n°3 metal guardpanels - n°3 rotating mold PTE guardpanels - n°1 rotating mold PTE climbing - n°1 timber or aluminium stairs - n°1 slope bridge - n°1 modular slide with crossbar - n°1 HDPE sheet playpanel
--------------------	--------------------------------------------------------------------------------------------------------------------------------------------------------------------------------------------------------------------------------------------------------------------------------------------------------------------------------------------------------------------------------------------------------------------------------------------

SECURITY AREA

820

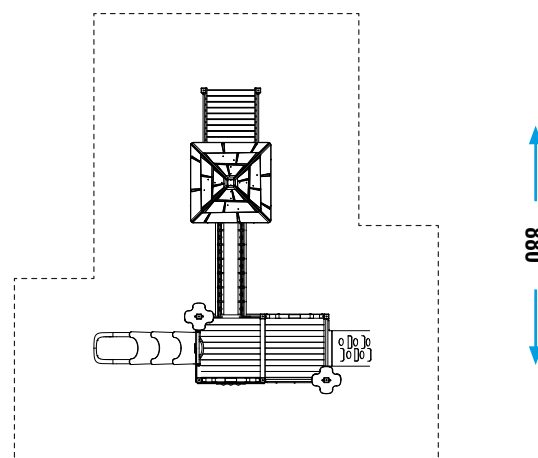

Make a proper security surface according to CFH. **Periodic maintenance is mandatory**, following manual supplied to customer.