



SLIDING

INTERACTIVE GAME



CATALOG COLLECTION	FUN COLLECTION
DIMENSIONS (L x W x H) in cm	570 x 330 x 290
MAXIMUM CFH	110
IMPACT ATTENUATING SURFACE	min. 48,50 m ² - MAX 54,00 m ²
SUGGESTED AGE OF USE	3 - 9
COMPOSITION	<ul style="list-style-type: none"> - n°8 timber or aluminium poles 9x9cm - n°2 timber or aluminium decks - n°1 gable roof - n°1 metal guardpanel - n°2 rotating mold PTE guardpanels - n°1 timber or aluminium closed stairs - n°1 slope bridge - n°1 modular slide - n°1 tube slide - n°1 HDPE sheet playpanel

SECURITY AREA

630

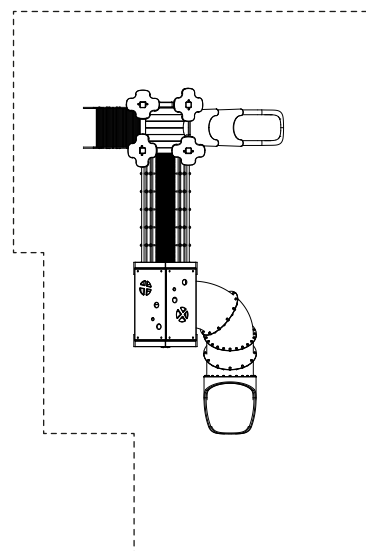

900

Make a proper security surface according to CFH. **Periodic maintenance is mandatory**, following manual supplied to customer.