

**PRODUCT SHEET**  
 REV 2.0 - EN201812  
**6017 MAIORCA**
**SLIDING****MEETING & ROLE PLAY****INTERACTIVE GAME**

<b>CATALOG COLLECTION</b>	FUN COLLECTION
<b>DIMENSIONS (L x W x H) in cm</b>	390 x 510 x 330
<b>MAXIMUM CFH</b>	125
<b>IMPACT ATTENUATING SURFACE</b>	min. 54,00 m <sup>2</sup> - MAX 56,00 m <sup>2</sup>
<b>SUGGESTED AGE OF USE</b>	3 - 10
<b>COMPOSITION</b>	<ul style="list-style-type: none"> <li>- n° 20 wooden or aluminium poles 9x9cm</li> <li>- n° 7 wooden or aluminum decks</li> <li>- n° 4 metal guardpanels</li> <li>- n° 2 rotational mold PTE guardpanels</li> <li>- n° 1 metal espalier</li> <li>- n°1 arched bridge</li> <li>- n° 4 decorative flower</li> <li>- n° 1 modular slide</li> <li>- n° 7 playpanels in PTE sheet</li> <li>- n° 2 climbing in PTE</li> </ul>

**SECURITY AREA**

690

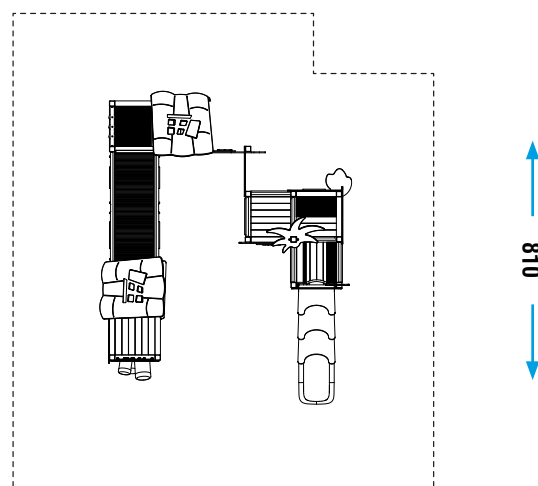

Make a proper security surface according to CFH. **Periodic maintenance is mandatory**, following manual supplied to customer.