

<b>CATALOG COLLECTION</b>	FUN COLLECTION
<b>DIMENSIONS (L x W x H) in cm</b>	375 x 310 x 330
<b>MAXIMUM CFH</b>	150
<b>IMPACT ATTENUATING SURFACE</b>	min. 38,00 m2 - MAX 45,00 m2
<b>SUGGESTED AGE OF USE</b>	6 - 12
<b>COMPOSITION</b>	<ul style="list-style-type: none"> <li>- n°4 timber or aluminium poles 9x9cm</li> <li>- n°1 timber or aluminium deck</li> <li>- n°1 gable roof</li> <li>- n°1 rotational mold PTE guardpanel</li> <li>- n°1 rotational mold PTE climbing</li> <li>- n°1 single slide with HDPE crossbar</li> <li>- n°1 rope climbing with ladder</li> <li>- n°1 metal playpanel</li> </ul>

**SECURITY AREA**  
610

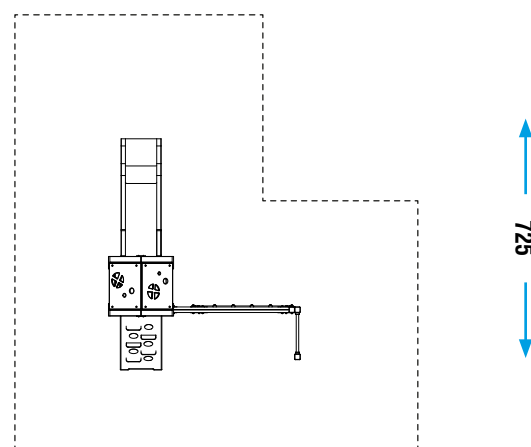

Make a proper security surface according to CFH. **Periodic maintenance is mandatory**, following manual supplied to customer.