

| | |
|-------------------------------------|------------------------------------------------------|
| CATALOG COLLECTION | FUN COLLECTION |
| DIMENSIONS (L x W x H) in cm | 560 x 345 x 320 |
| MAXIMUM CFH | 125 |
| IMPACT ATTENUATING SURFACE | min. 48,50 m ² - MAX 55,25 m ² |
| SUGGESTED AGE OF USE | 3 - 12 |

COMPOSITION

- n°9 timber or aluminium poles 9x9cm
- n°2 timber or aluminium decks
- n°1 gable roofs
- n°3 rotating mold PTE guardpanels
- n°1 rotating mold PTE climbing
- n°1 metal playpanel
- n°1 curved bridge
- n°2 modular slides with HDPE crossbar
- n°1 HDPE sheet flower decoration

SECURITY AREA

645

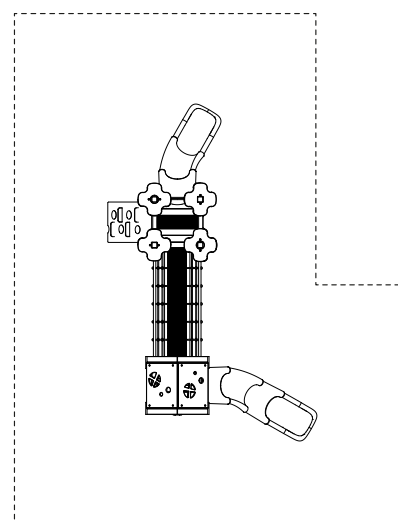

Make a proper security surface according to CFH. **Periodic maintenance is mandatory**, following manual supplied to customer.