

<b>CATALOG COLLECTION</b>	PARTY LINE
<b>DIMENSIONS (L x W x H) in cm</b>	430 x 370 x 240
<b>MAXIMUM CFH</b>	100
<b>IMPACT ATTENUATING SURFACE</b>	min. 42,50 m <sup>2</sup> - MAX 48,75 m <sup>2</sup>
<b>SUGGESTED AGE OF USE</b>	4 - 9

- COMPOSITION**
- n°14 timber or aluminium poles 9x9cm
  - n°4 timber or aluminium decks
  - n°10 HDPE sheet guardpanels
  - n°1 arch bridge
  - n°1 ramp bridge
  - n°1 rotating mold PTE climb
  - n°2 modular slides
  - n°2 HDPE sheet playpanels

**SECURITY AREA**

670

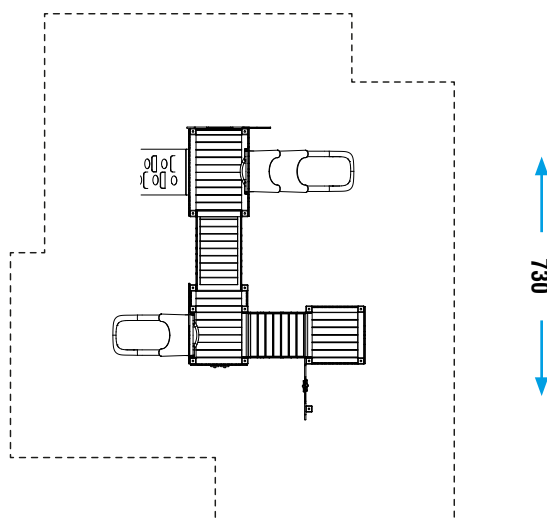

Make a proper security surface according to CFH. **Periodic maintenance is mandatory**, following manual supplied to customer.