



SLIDING



CLIMBING



CATALOG COLLECTION	PARTY LINE
DIMENSIONS (L x W x H) in cm	370 x 210 x 280
MAXIMUM CFH	100
IMPACT ATTENUATING SURFACE	min. 35,00 m ² - MAX 35,00 m ²
SUGGESTED AGE OF USE	4 - 9

COMPOSITION

- n°6 timber or aluminium poles 9x9cm
- n°2 timber or aluminium decks
- n°1 HDPE sheet roof
- n°3 metal guardpanels
- n°2 HDPE sheet guardpanels
- n°1 modular slide
- n°1 HDPE sheet climbing
- n°1 HDPE sheet and metal climbing
- n°1 perch
- n°1 bench with table

SECURITY AREA

510

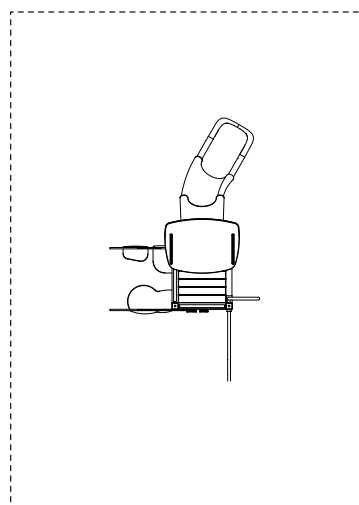

Make a proper security surface according to CFH. **Periodic maintenance is mandatory**, following manual supplied to customer.