



CATALOG COLLECTION	PARTY LINE
DIMENSIONS (L x W x H) in cm	640 x 320 x 285
MAXIMUM CFH	90 (135)
IMPACT ATTENUATING SURFACE	min. (14,00) 46,50 m ² - MAX 60,00 m ²
SUGGESTED AGE OF USE	3 - 9

COMPOSITION
- n°6 timber or aluminium poles 9x9cm
- n°2 timber or aluminium decks
- n°3 metal guardpanels
- n°1 HDPE sheet guardpanel
- n°1 timber or aluminium closed stairs
- n°2 modular slides
- n°1 HDPE sheet playpanel
- n°1 HDPE sheet bench
- n°1 swing attachment

SECURITY AREA

750

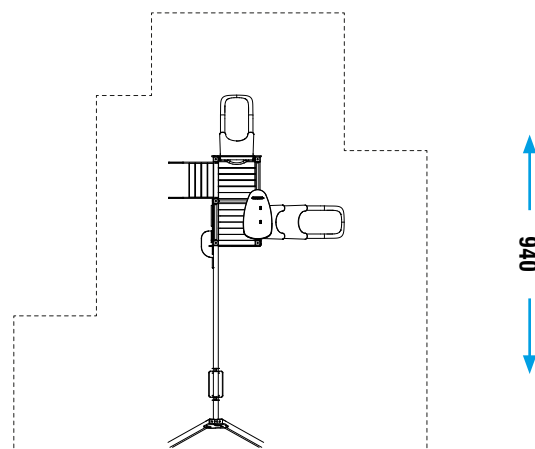

Make a proper security surface according to CFH. **Periodic maintenance is mandatory**, following manual supplied to customer.