

| | |
|-------------------------------------|--|
| CATALOG COLLECTION | PARTY LINE |
| DIMENSIONS (L x W x H) in cm | 350 x 400 x 300 |
| MAXIMUM CFH | 155 |
| IMPACT ATTENUATING SURFACE | min. 41,00 m ² - MAX 45,50 m ² |
| SUGGESTED AGE OF USE | 4 - 12 |

SECURITY AREA

← 650 →

COMPOSITION

- n°7 octagonal aluminium poles 9x9cm
- n°2 timber or aluminium decks
- n°4 metal guardpanels
- n°2 HDPE sheet decoration
- n°1 double modular slide
- n°1 HDPE sheet playpanel
- n°1 metal playpanel
- n°2 HDPE sheet guardpanels
- n°1 HDPE sheet climber
- n°1 metal ladder

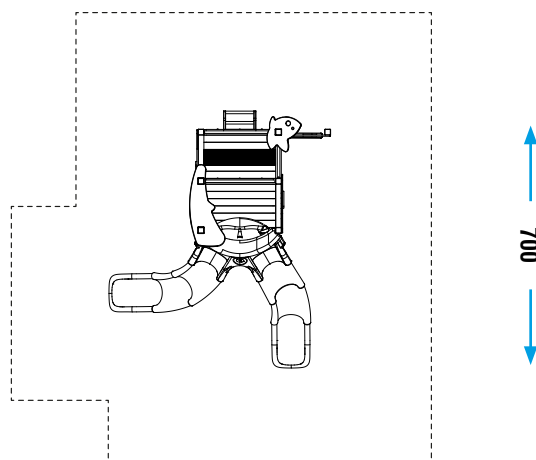

Make a proper security surface according to CFH. **Periodic maintenance is mandatory**, following manual supplied to customer.