

CATALOG COLLECTION	PARTY LINE
DIMENSIONS (L x W x H) in cm	350 x 400 x 300 (650 x 700)
MAXIMUM CFH	125
IMPACT ATTENUATING SURFACE	min. 41,00 m ² - MAX 45,50 m ²
SUGGESTED AGE OF USE	4 - 12

SECURITY AREA

650

COMPOSITION

- n°8 octagonal aluminium poles 9x9cm
- n°3 timber or aluminium decks
- n°5 metal guardpanels
- n°2 HDPE sheet decoration
- n°1 modular slide
- n°1 double modular slide
- n°1 HDPE sheet playpanel
- n°1 HDPE sheet guardpanels
- n°2 HDPE sheet climbers
- n°1 metal ladder
- n°1 timber or aluminium closed stairs

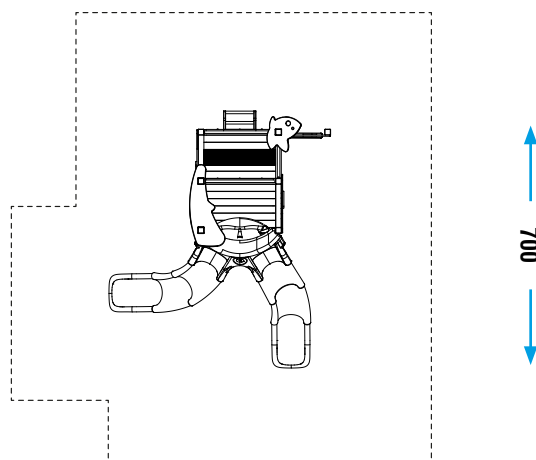

Make a proper security surface according to CFH. **Periodic maintenance is mandatory**, following manual supplied to customer.