

# PRODUCT SHEET

REV 2.0 - EN201812

## 8882 MOUNT QWORT



## SLIDING



## CLIMBING



## INTERACTIVE GAME



<b>CATALOG COLLECTION</b>	PARTY LINE
<b>DIMENSIONS (L x W x H) in cm</b>	350 x 350 x 330
<b>MAXIMUM CFH</b>	125
<b>IMPACT ATTENUATING SURFACE</b>	min. 35,50 m <sup>2</sup> - MAX 42,25 m <sup>2</sup>
<b>SUGGESTED AGE OF USE</b>	6 - 10
<b>COMPOSITION</b>	<ul style="list-style-type: none"> <li>- n°6 timber or aluminium poles 9x9cm</li> <li>- n°2 timber or aluminium decks</li> <li>- n°4 metal guardpanels</li> <li>- n°3 HDPE sheet guardpanels</li> <li>- n°1 rotating mold PTE climbing</li> <li>- n°1 HDPE sheet climbing</li> <li>- n°1 metal tubular climbing</li> <li>- n°1 HDPE sheet playpanel</li> <li>- n°1 modular slide</li> </ul>

**SECURITY AREA**

← 650 →

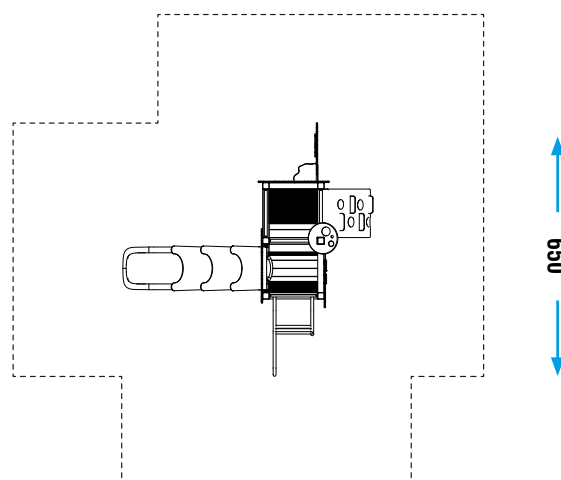

Make a proper security surface according to CFH. **Periodic maintenance is mandatory**, following manual supplied to customer.