

CATALOG COLLECTION	CLASSIC COLLECTION
DIMENSIONS (L x W x H) in cm	880 x 845 x 360
MAXIMUM CFH	140
IMPACT ATTENUATING SURFACE	min. 106,50 m ² - MAX 156,00 m ²
SUGGESTED AGE OF USE	3 - 12
COMPOSITION	<ul style="list-style-type: none"> - n°14 timber or aluminium poles 9x9cm - n°4 timber or aluminium decks - n°2 pyramid roofs in rotational PTE - n°12 HDPE sheet guardpanels - n°1 timber or aluminium stairs - n°1 arch bridge - n°1 slope bridge - n°1 double slide with HDPE crossbar - n°1 single slide with HDPE crossbar - n°1 tube slide - n°1 HDPE sheet playpanel - n°1 rotating mold PTE climbing

SECURITY AREA

1195

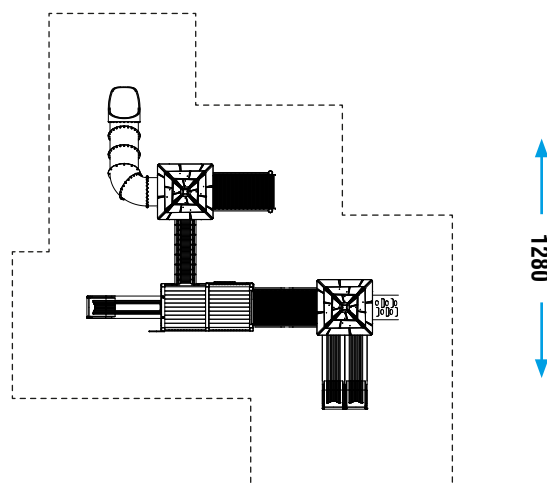

Make a proper security surface according to CFH. **Periodic maintenance is mandatory**, following manual supplied to customer.