

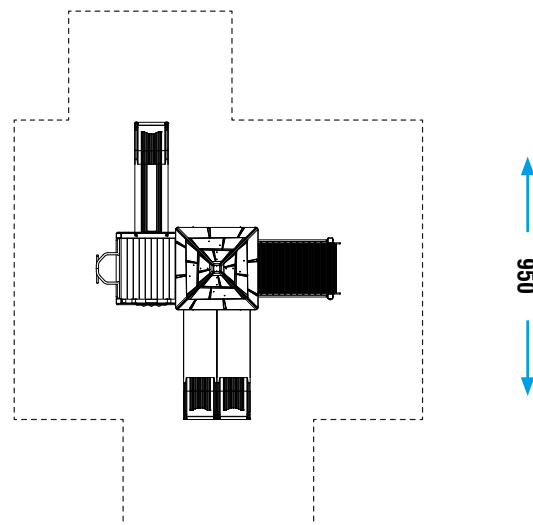

<b>CATALOG COLLECTION</b>	CLASSIC COLLECTION
<b>DIMENSIONS (L x W x H) in cm</b>	450 x 550 x 340
<b>MAXIMUM CFH</b>	140
<b>IMPACT ATTENUATING SURFACE</b>	min. 48,25 m <sup>2</sup> - MAX 71,25 m <sup>2</sup>
<b>SUGGESTED AGE OF USE</b>	3 - 9

<b>COMPOSITION</b>	<ul style="list-style-type: none"> <li>- n°6 timber or aluminium poles 9x9cm</li> <li>- n°2 timber or aluminium decks</li> <li>- n°1 pyramid roof in rotational PTE</li> <li>- n°2 rotating mold PTE guardpanels</li> <li>- n°1 timber or aluminium stairs</li> <li>- n°1 double slide with HDPE crossbar</li> <li>- n°1 single slide with HDPE crossbar</li> <li>- n°1 zig-zag perch</li> <li>- n°2 HDPE sheet playpanels</li> </ul>
--------------------	---

**SECURITY AREA**  
750



Make a proper security surface according to CFH. **Periodic maintenance is mandatory**, following manual supplied to customer.