



SLIDING



CLIMBING



INTERACTIVE GAME

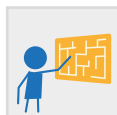

<b>CATALOG COLLECTION</b>	CLASSIC COLLECTION
<b>DIMENSIONS (L x W x H) in cm</b>	600 x 425 x 350
<b>MAXIMUM CFH</b>	125
<b>IMPACT ATTENUATING SURFACE</b>	min. 53,00 m <sup>2</sup> - MAX 63,00 m <sup>2</sup>
<b>SUGGESTED AGE OF USE</b>	3 - 12
<b>COMPOSITION</b>	<ul style="list-style-type: none"> <li>- n°8 timber or aluminium poles 9x9cm</li> <li>- n°2 timber or aluminium decks</li> <li>- n°2 pyramid roofs in rotational mold PTE</li> <li>- n°1 metal guardpanel</li> <li>- n°1 rotating mold PTE guardpanel</li> <li>- n°2 HDPE sheet guardpanels</li> <li>- n°1 timber or aluminium stairs</li> <li>- n°1 slope bridge</li> <li>- n°1 tube slide</li> <li>- n°1 rotating mold PTE climbing</li> <li>- n°3 HDPE sheet playpanels</li> </ul>

SECURITY AREA

775

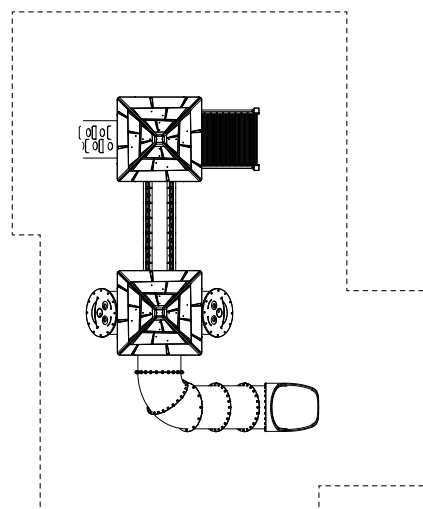

900

Make a proper security surface according to CFH. **Periodic maintenance is mandatory**, following manual supplied to customer.