

# Cone Giratório

ref. B0100101

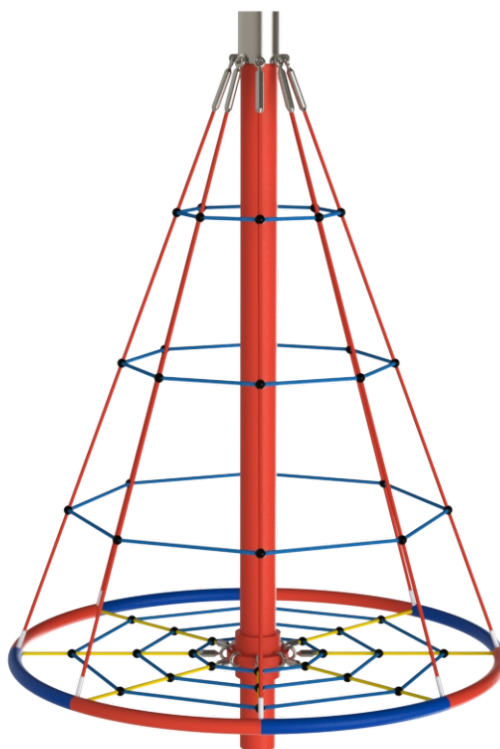

+2 YEARS

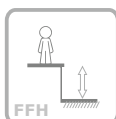

2.25 m

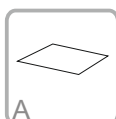

29 m<sup>2</sup>

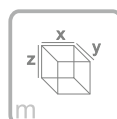

xy=ø2.00  
z=3.00

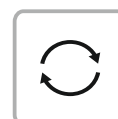

360°

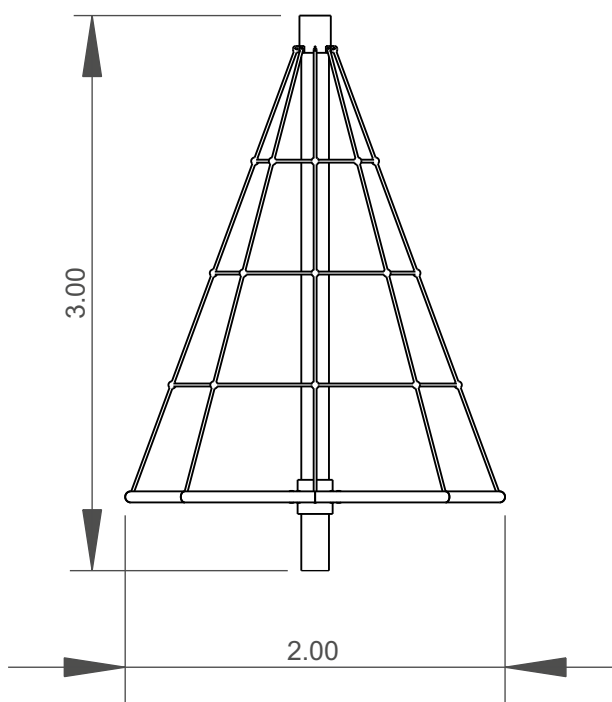



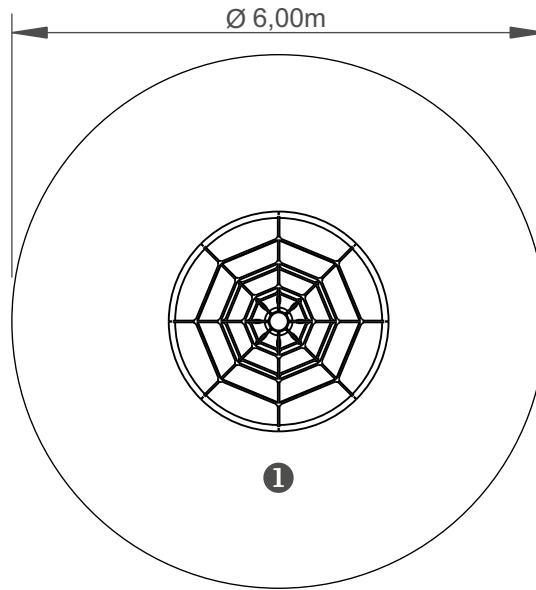

# Equipment Information:



— Impact area  
 - - Free space

EN 1176-1



.....	1
	2.25
	29
	29

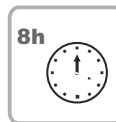
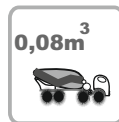

# Technical Information:

1 - Spinning Cone  2.25m

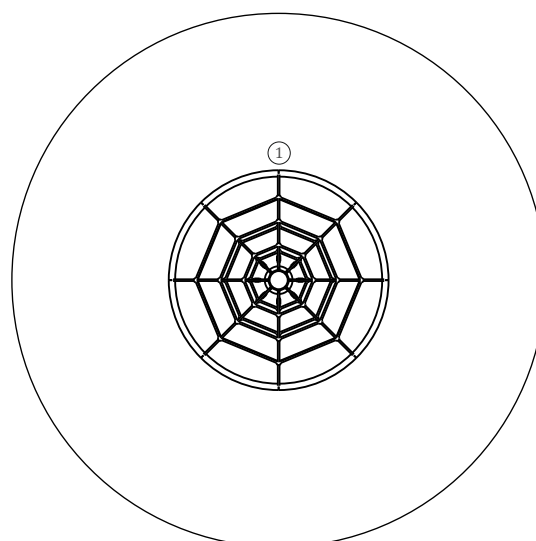

# Technical Characteristics:



**bragmaia**<sup>®</sup>

**Net:** Ø16mm steel ropes coated in reinforced polypropylene fibers, connection accessories in HDPE with U.V. protection, fixing elements in galvanized hot steel;

## **Metal parts**

**Vertical Post:** Stainless Steel AISI 304;

## **Fixation System:**

**Type C** - Standard fixation system composed by posts applied directly in the ground with concrete;

## **Screws and accessories**

**Screws:** Galvanized steel or optionally stainless steel AISI 304;

**Capsules:** PP Polypropylene plastic;



100% recyclable;

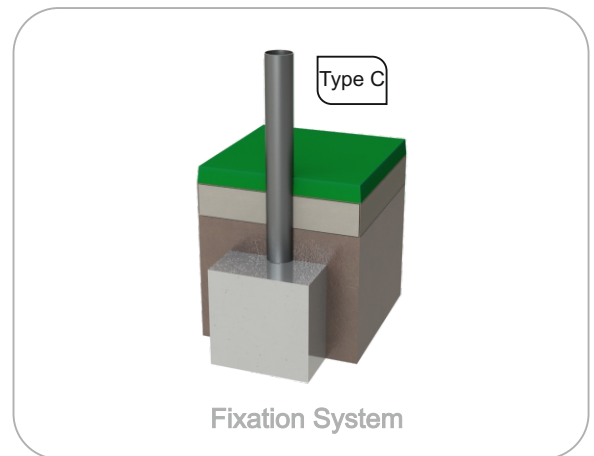

# Playful Activities:



**Amuse:** While they have fun, children acquire several capacities, since physical abilities to social interactions.



**Socialize:** The socialization and imagination are necessary in all games. All of it creates a relation between children and arouses the sense of coexistence and solidarity.



**Play:** Develops both patience, sharing and sportsmanship.



**Climbing:** A movement to develop children motor skills, body control, balance and coordination, which stimulates the motor capacity an own body security.