

BAT 2

PRODUCT DATA SHEET

Jūrmalas Mežaparki Ltd.

1 Garkalnes street, Jūrmala
+371 6773 2317, www.jmp.lv



Construction are made from glued wood, galvanized steel and HDPE.

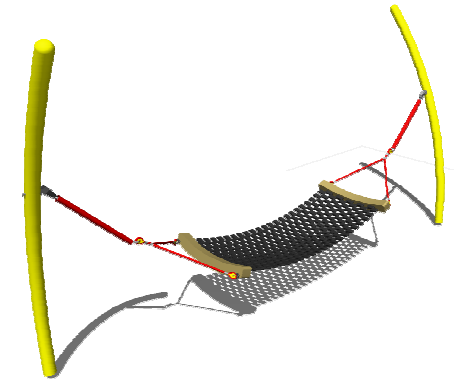
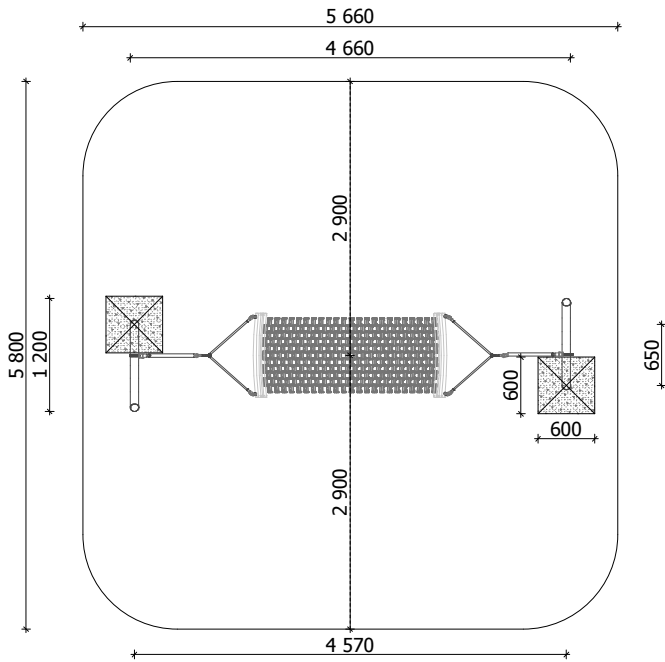

1 child

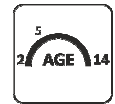

Children from 3 years

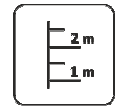

The Fall height H=1.38 m



Weight 255 kg



Assembly 4 h (without excavation and concreting)

Minimal required area - 25 m²

Length: 4 660 mm
Width: 1 200 mm
Height: 2 540 mm

Playground are provided for outdoor use in supervising of adults

Length of safety area: 5 660 mm
Width of safety area: 5 800 mm
Required safety area: 25 m²

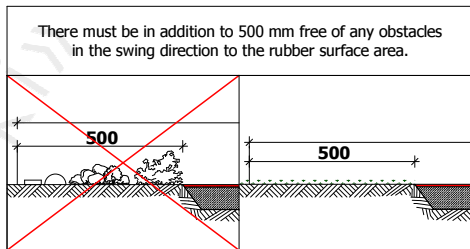

There must be in addition to 500 mm free of any obstacles in the swing direction to the rubber surface area.

Equipment safety checkings must be performed once in a week in high vandalism risk areas.
Maintenance are required once in every 3 months, depending on usage

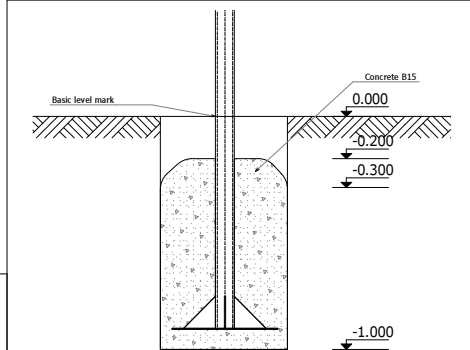

Play equipment are established with concreted steel foundation in equipment location. Equipment are suitable for use in two days after concreting, when the foundation are totally solid. During assembling there are not children allowed in area.

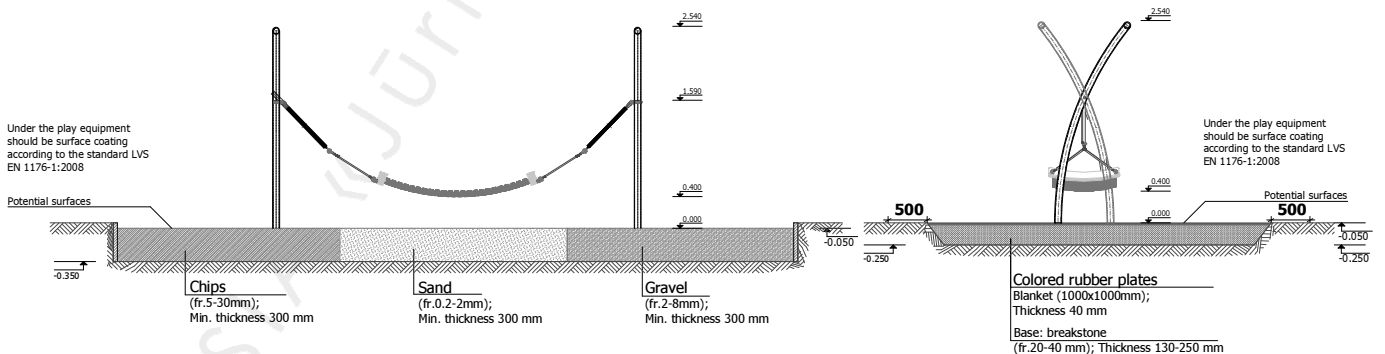

Transportation: One palette: 1 palette 1 200 x 1 000 x 3 000 mm

Spare parts: All needed spare parts and elements, when warranty time expires can be ordered in „Jūrmalas Mežaparki” Ltd., and all the goods will be ready for delivery in 3 days.

According to LVS EN 1176:2008

Manufactured according to:

