

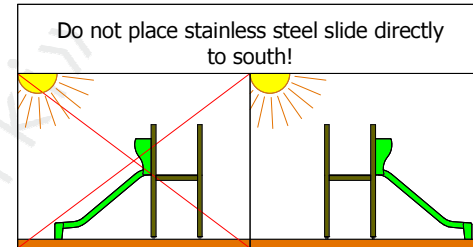

Construction are made from glued wood, galvanized steel and HDPE.

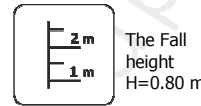
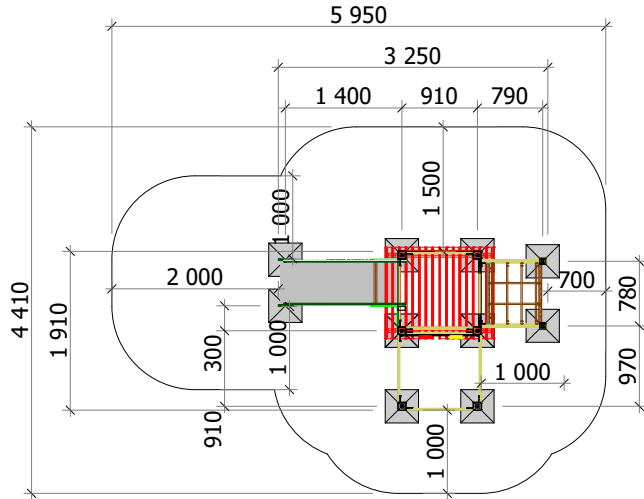

Equipment safety checkings must be performed once in a week in high vandalism risk areas.

Maintainance are required once in every 3 months, depending on usage

Minimal required area - 21 m<sup>2</sup>

Length: 3 250 mm  
Width: 1 910 mm  
Height: 2 650 mm

Playground are provided for outdoor use in supervising of adults

Length of safety area: 5 950 mm  
Width of safety area: 4 410 mm  
Required safety area: 21 m<sup>2</sup>

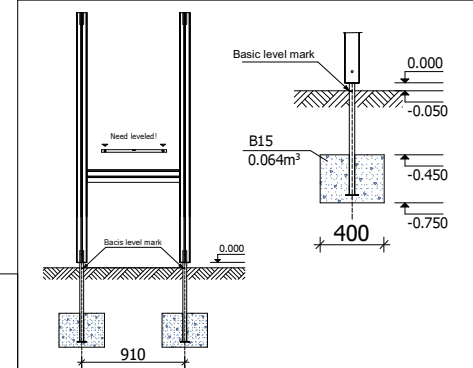

Play equipment are established with concreted steel foundation in equipment location. Equipment are suitable for use in two days after concreting, when the foundation are totally solid. During assembling there are not children allowed in area.

### Adequate temperature

T<sub>min</sub> -33.2 °C  
T<sub>max</sub> +58.7 °C



### Snow load

1.10 kN/m<sup>2</sup>



### Wing load

Strength 323.71 N

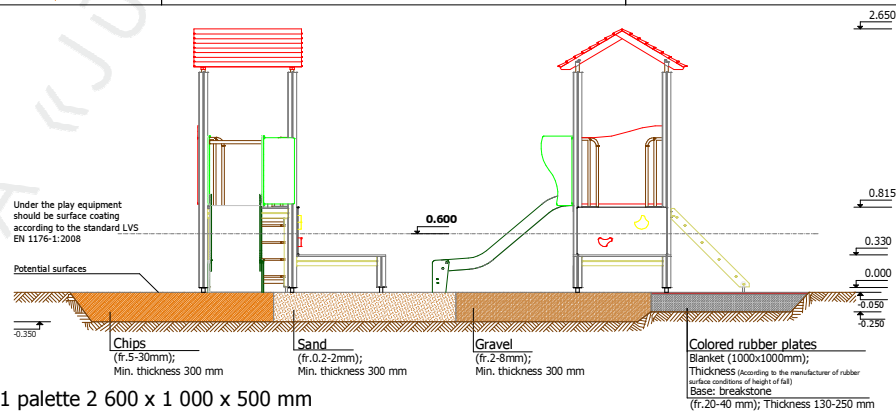

**Transportation:** One palette: 1 palette 2 600 x 1 000 x 500 mm

**Spare parts:** All needed spare parts and elements, when warranty time expires can be ordered in „Jūrmalas Mežaparki” Ltd., and all the goods will be ready for delivery in 3 days.

According to LVS EN 1176:2008

Manufactured according to:

