

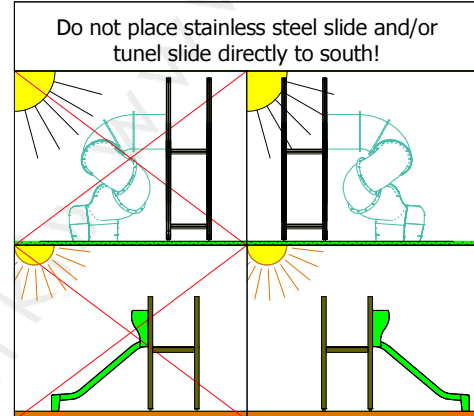

Construction are made from glued wood, galvanized steel and HDPE.

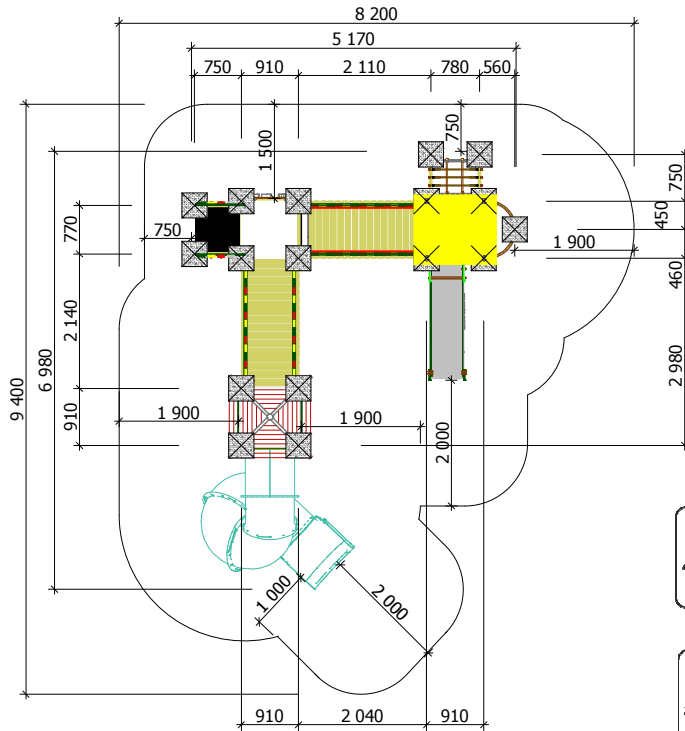

MAX
25 children

AGE
5 - 14 years

2 m
1 m
The Fall height
H=2.00 m

KG
Weight
860 kg

h
Assembly
22 h
(without excavation and concreting)

Minimal required area - 53 m²

Length: 5 170 mm
Width: 6 980 mm
Height: 3 980 mm

Playground are provided for outdoor use in supervising of adults

Length of safety area: 8 200 mm
Width of safety area: 9 400 mm
Required safety area: 53 m²

Equipment safety checkings must be performed once in a week in high vandalism risk areas.

Maintainance are required once in every 3 months, depending on usage

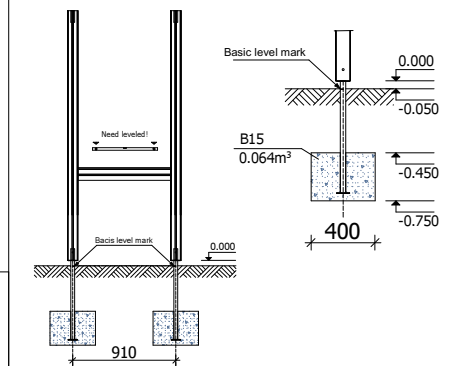

Play equipment are established with concreted steel foundation in equipment location. Equipment are suitable for use in two days after concreting, when the foundation are totally solid. During assembling there are not children allowed in area.

Adequate temperature

T_{zemāka} -33.2 °C
T_{augstākā} +54.1 °C



Snow load

1.05 kN/m²



Wing load

Stiprums 460 N

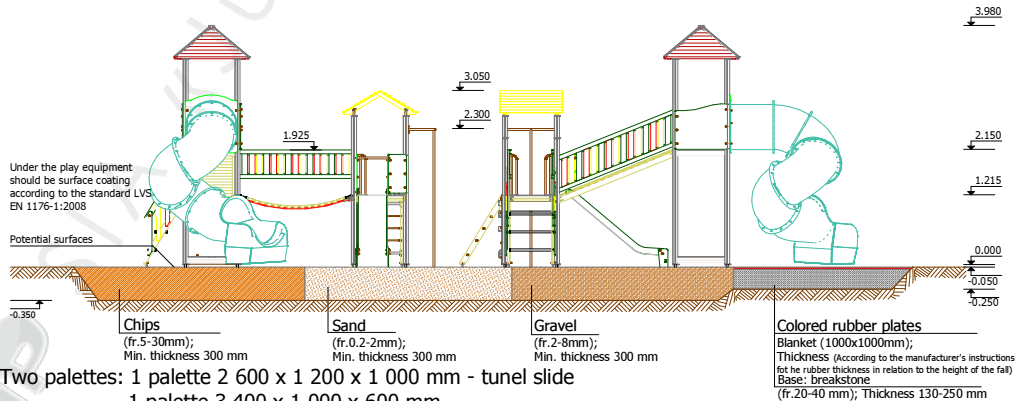

Transportation: Two palettes: 1 palette 2 600 x 1 200 x 1 000 mm - tunnel slide
1 palette 3 400 x 1 000 x 600 mm

Spare parts: All needed spare parts and elements, when warranty time expires can be ordered in „Jūrmalas Mežaparki” Ltd., and all the goods will be ready for delivery in 3 days.

According to LVS EN 1176:2008

Manufactured according to:

