

Zea de Cordas

ref. ELDAN029MCA

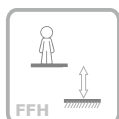

4 Users



FFH

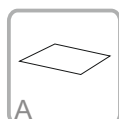

A

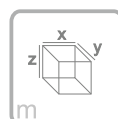

x= 7.20
y= 3.55
z= 4.45

Data Sheet

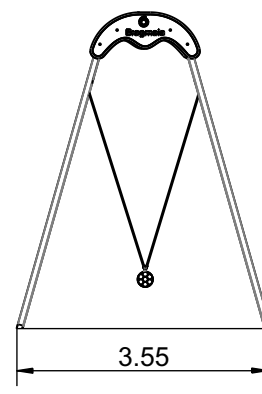
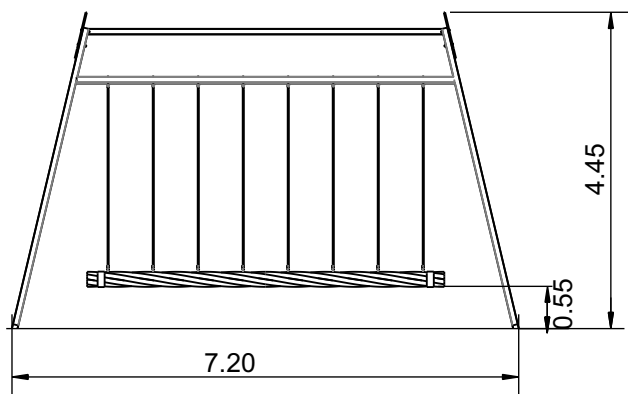



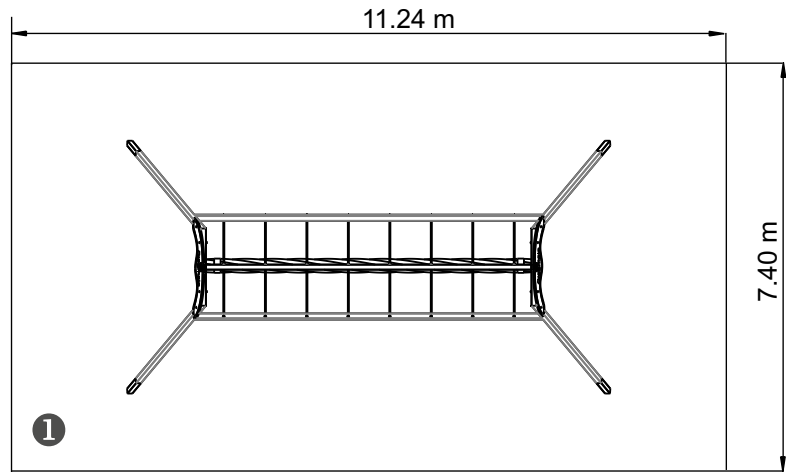

Equipment Information:



— Impact area
 - - Free space

EN 1176-1,2



.....	①
	2.05
	83
	83

0,32m³



2h



2x



KG



KG



Technical Information:

1 - Rope Swing  2.05m

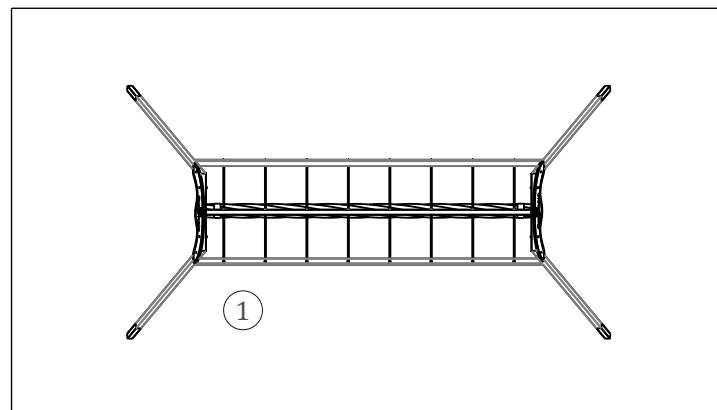



bragmaia®

Technical Characteristics:

Panels

HDPE: Monocolour/bicolour high density polyethylene. It is a polymer so it is characterized by its resistance to corrosion and chemical products. By its capacity of elasticity and lightweight, it offers high resistance to impacts, and, therefore, very difficult to break. The non-slip surface offers security to children and the synthetic base prevents grow of bacterias and fungus. No need for maintenance;

Ropes: Ropes Ø200mm reinforced with steel covered polypropylene fibers, attachment and fixing accessories in HDPE with U.V. protection, chains in hot dip galvanized steel.

Chains: Fixed galvanized steel chains.

Metal parts

Tubes:

Iron: Anticorrosive treatment of hot dip galvanizing in accordance with EN ISO 1461; Tubes: 80x80x3 and with 70x70x3.

Fixation System:

Type B - Standard fixation system composed by steel base screwed to the ground with steel anchors;

Type C - Standard fixation system composed by posts applied directly in the ground with concrete;

Screws and accessories

Screws: Galvanized steel or optionally stainless steel AISI 304;

Capsules: PP Polypropylene plastic;



100% recyclable;

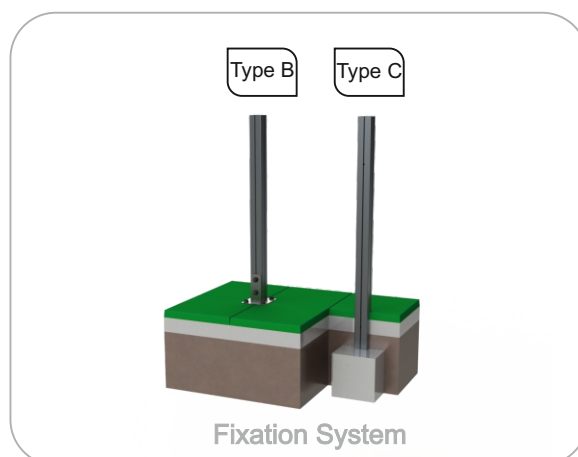

Playful Activities:



Amuse: While they have fun, children acquire several capacities, since physical abilities to social interactions.



Socialize: The socialization and imagination are necessary in all games. All of it creates a relation between children and arouses the sense of coexistence and solidarity.



Play: Develops both patience, sharing and sportsmanship.



Swinging: The nervous system is stimulated by this movement, mainly the psychomotor system and the sight. It is also relaxing and, in addition, it helps developing the balance and coordination faculties.