

ELE400050

Tower



The Tower's movement flow and versatile play events attract children and make them want to come back again and again. The accessible stairway eases access for children with mobility challenges. The desk under the platform is usable for all. The inclined climbing wall offers another way up. From elevated level, either the slide or the curly climber offer stomach tickling rides to the ground. The rotating slide movement of the curly climber, apart from being hugely joyful, trains the spatial awareness and the sense of balance. Both these motor skills are important for e.g. managing traffic safely. Sliding is a playground favorite, and the tower slide trains the trunk stability of the child, too. This, combined with a good sense of balance, is necessary to e.g. sit still. All in all, the Tower is great play fun and yet great training of motor skills and muscle strength, preparing the child for life.

Product Line	ELEMENTS™
Category	ELEMENTS™ PRESCHOOL
Age group	2 - 6
Max. fall height (CM)	217
Total height (CM)	300
Safety Zone	38 m2



SOCIALIZE



CLIMB



SLIDE



CONSTRUCT



DRAMATIC PLAY



INCLUSIVE



**SUR-
FACE**



ADA / INCLUSIVE

ASTM

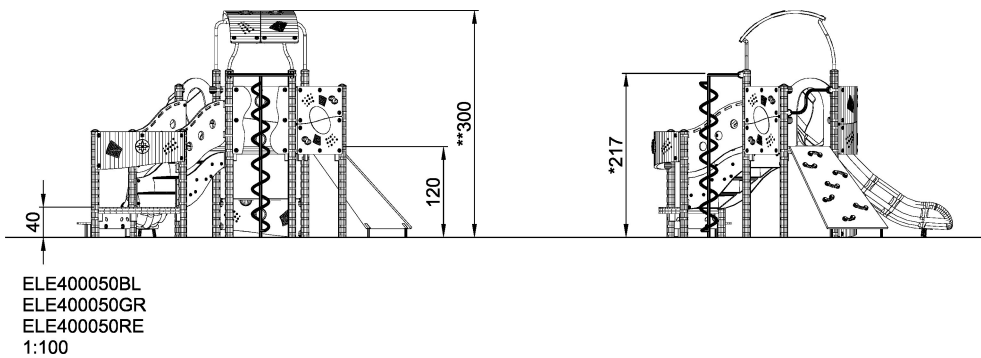
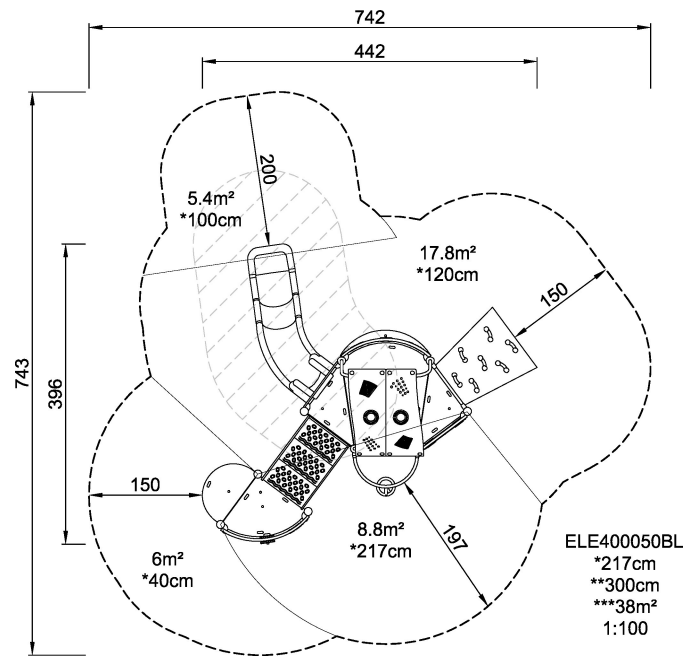

* = Highest designated play surface.
** = Total height of product.

Weight/heaviest parts	kg.	Installation (Manpower)	Persons
Concrete required	NaN m3	Installation (Hours)	Hours
Foundation amount/footing	NaN	Excavation	NaN m3