

FSW20501

Wide Overhead Ladder

KOMPAN[®]
Let's play



The overhead ladder, also known as the monkey bar, may be the most famous of all obstacle course elements. The goal is to get to the other side without using your feet. This overhead ladder is wide and high to ensure anyone can hang and move freely. To make sure that everyone can reach the overhead ladder we added 4 stepping pods at different heights. The overhead ladder has a clear instruction sign showing the basic exercise and a QR code. By clicking on the QR code users can connect to the KOMPAN fitness App, where they will find multiple exercises and workouts at every level.

Product Line	Outdoor Fitness
Category	Street Workout & Calisthenics
Age group	13+
Max. fall height (CM)	133
Total height (CM)	240
Safety Zone	18.8 m ²



**SUR-
FACE**

**IN-
GROU.**



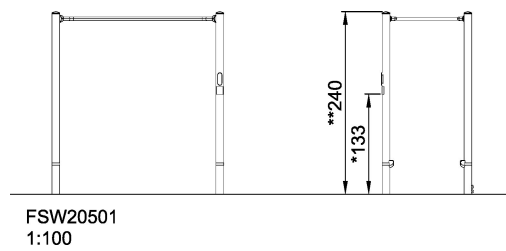
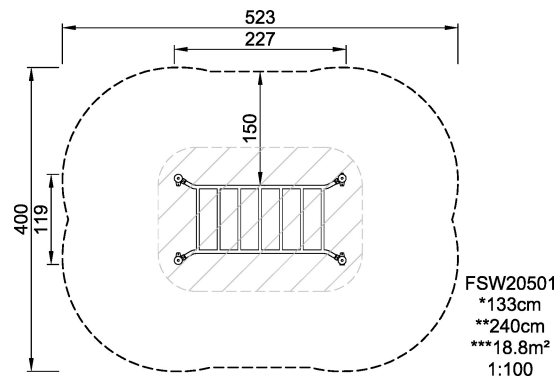

* = Highest designated play surface.

** = Total height of product.

Weight/heaviest parts	kg.	Installation (Manpower)	Persons
Concrete required	NaN m ³	Installation (Hours)	Hours
Foundation amount/footing	NaN	Excavation	NaN m ³