

# Bars

ref. G2705I



www.bragmaia.com



Data Sheet

+12



2 Users

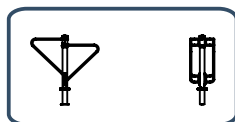

1800x630x1345mm

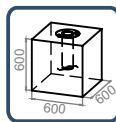

Mode of Fixation

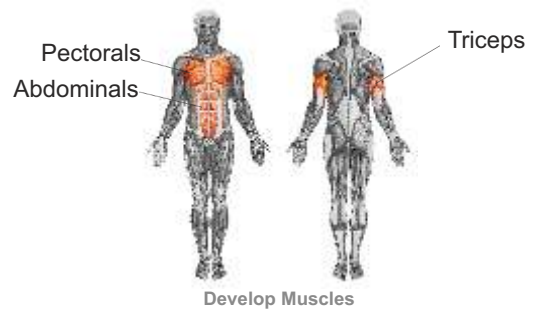

## Security Area:

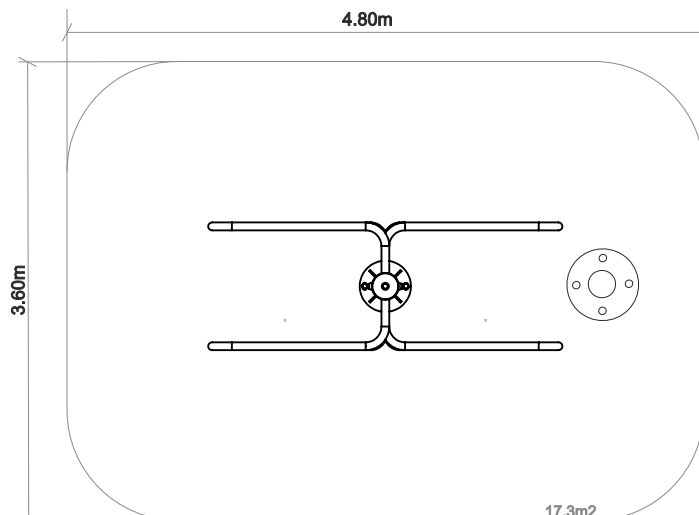

## Technical Characteristics:

Materials

Structure: Stainless Steel AISI 304;

Plastic parts: HDPE;

Ironmongery: Stainless Steel AISI 304;

Finishing: Brushed;

Type of Fixation: by 1 negative provided;

Optional: Stainless Steel AISI 316;

Note: You must ensure that the equipment is correctly installed at the negative. Align the drilling equipment before drilling negative as illustrated by picture.

## Maintenance

Every week: carry out a visual check on the general state of the element to make sure there are no breakages or damages to endanger users;

Every month: check that the joints move smoothly. Grease them if necessary. Ensure that the element is as structurally stable as when it was new. Check the state of all the screws, bolts and their protection;

Every year: check there is no corrosion on the metal legs. Check all ground fixings;

# BARS



Ref.:

**C27051**

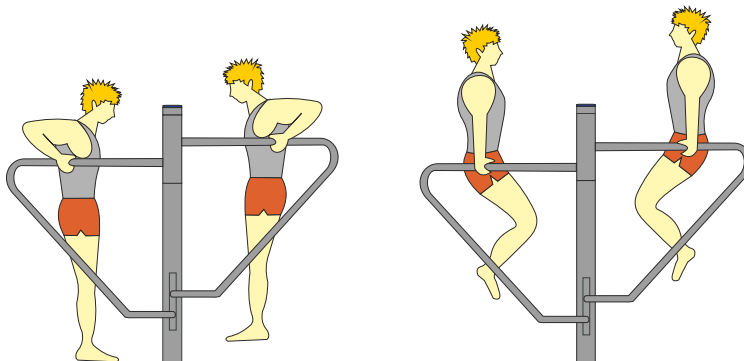

**+12**



2 Users

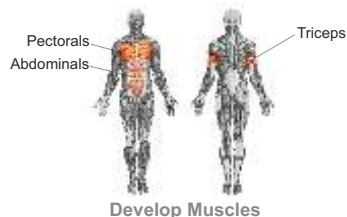

25 repetitions  
1 to 3 series  
Rest 30/60 seconds

**EXECUTION MODE**: Grab the lateral bars with both hands and stretch your upper limbs, elevating your upper body and then return to the starting position.



**Caution**: Consult your doctor before performing these exercises. Children should be supervised by an adult.



Bragmaia: Zona Industrial das Cantarias, Rua Arq.º Viana Lima, lote 131, 5300-427 Bragança - Portugal