

Ski

ref. G2803l



www.bragmaia.com



Data Sheet

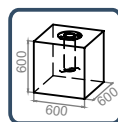
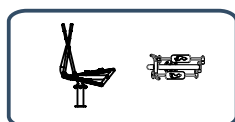

1 User

1140x440x450mm

Mode of Fixation

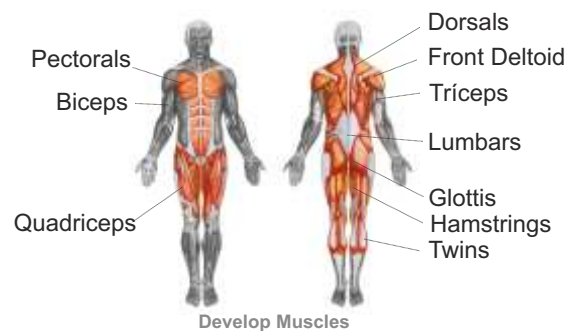

Security Area:

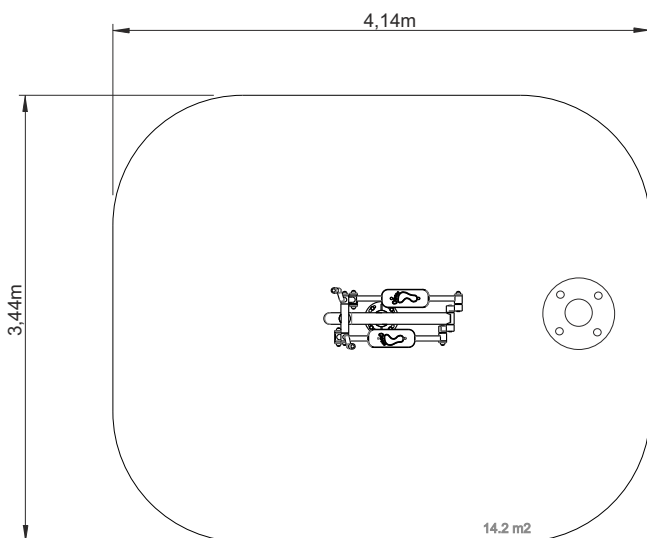

Technical Characteristics:

Materials

Structure: Stainless Steel AISI 304;

Plastic parts: HDPE;

Ironmongery: Stainless Steel AISI 304;

Bearings: SKF rigid spheres with a shielded career on both sides (no need to maintenance and lubrication);

Finishing: Brushed;

Type of Fixation: by 1 negative provided;

Optional: Stainless Steel AISI 316;

Note: You must ensure that the equipment is correctly installed at the negative. Align the drilling equipment before drilling negative as illustrated by picture.

Maintenance

Every week: carry out a visual check on the general state of the element to make sure there are no breakages or damages to endanger users;

Every month: check that the joints move smoothly. Grease them if necessary. Ensure that the element is as structurally stable as when it was new. Check the state of all the screws, bolts and their protection;

Every year: check there is no corrosion on the metal legs. Check all ground fixings;

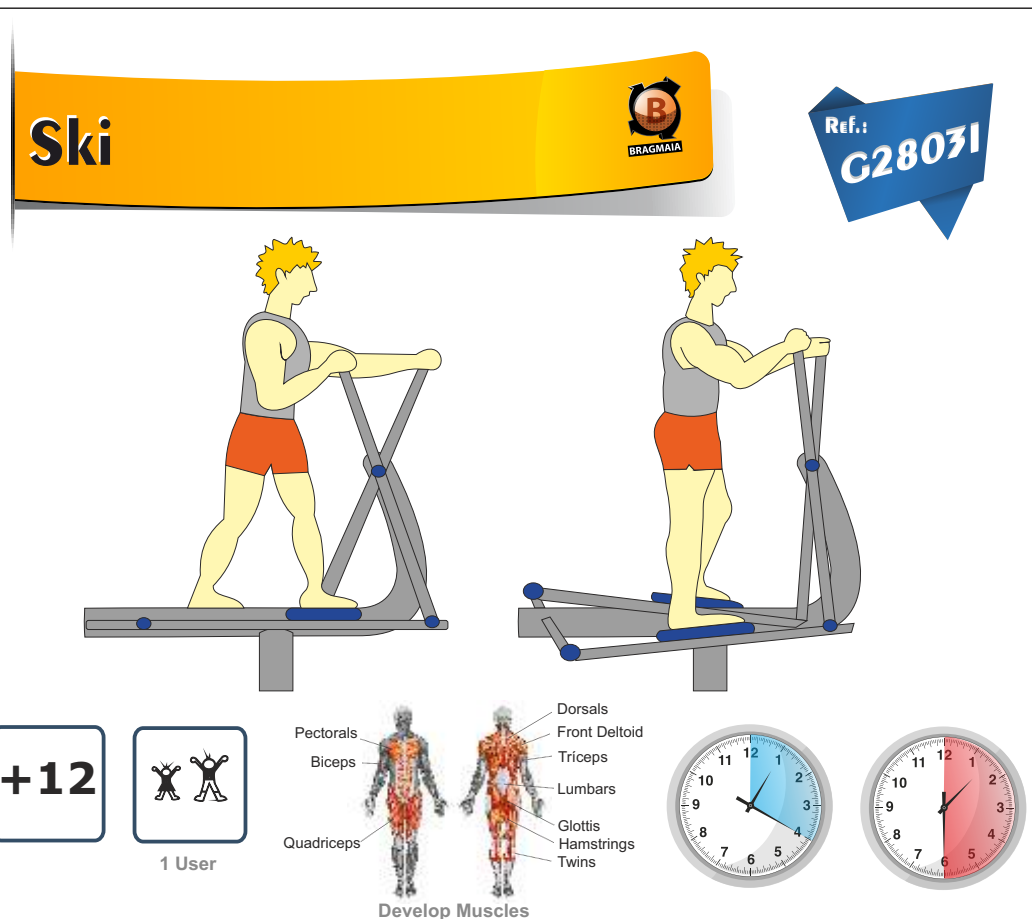

EXECUTION MODE: Climb to the machine and grab the handles (black area) with both hands and move the lower and upper limbs as if you were walking. Normal bipedal posture and look forward with your chin up.



Caution: Consult your doctor before performing these exercises. Children should be supervised by an adult.



Bragmaia: Zona Industrial das Cantarias, Rua Arq.º Viana Lima, lote 131, 5300-427 Bragança - Portugal