

KPL101201

Play tower with roof & slide, wood posts & plastic slide



This condensed play unit offers the basic experiences of climbing or crawling up and down and sliding. The deep entry platform has enough room to take a break, too. Crawling and sliding are fundamental to the young child's development of motor skills. Apart from being stomach tickling fun, sliding trains the vestibular system. Climbing trains the young child's cross-body coordination and thus proprioception, both important to the young child's mastery of the physical skills that form a basis for both social skills and thinking skills.

Product Line	Traditional Play
Category	SIMPLY PLAY towers
Age group	1 - 4
Max. fall height (CM)	100
Total height (CM)	214
Safety Zone	15 m ²



IN-
GROU.

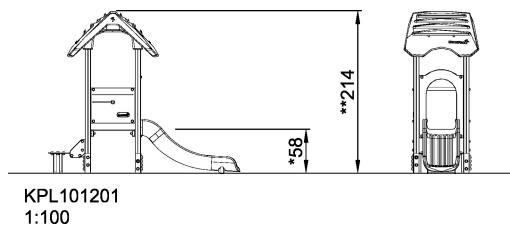
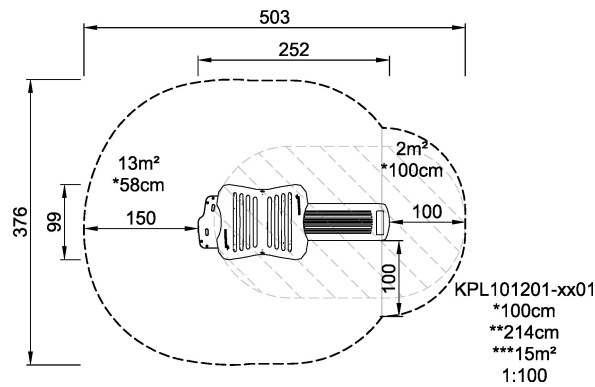

* = Highest designated play surface.
** = Total height of product.

Weight/heaviest parts	kg.	Installation (Manpower)	Persons
Concrete required	NaN m3	Installation (Hours)	Hours
Foundation amount/footing	NaN	Excavation	NaN m3