

# KPX125 Cross Trainer



The Cross Trainer is perfect for those looking to improve their fitness. During the workout you will experience a mild resistance only, making it easy on knees and joints while still providing an optimal exercise for people to improve their personal fitness. The equipment is available with hot dipped galvanized surface treatment and optional powder coated top layer in silver grey color RAL9007. If requested a curved roof can be added to the center pole.

<b>Product Line</b>	Outdoor Fitness
<b>Category</b>	Circuit Training
<b>Age group</b>	13+
<b>Max. fall height (CM)</b>	55
<b>Total height (CM)</b>	184
<b>Safety Zone</b>	13.1 m <sup>2</sup>



**SUR-  
FACE**

**IN-  
GROU.**



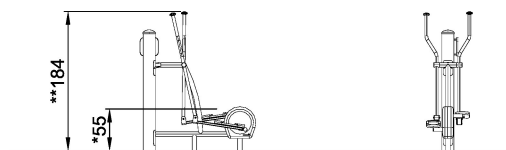
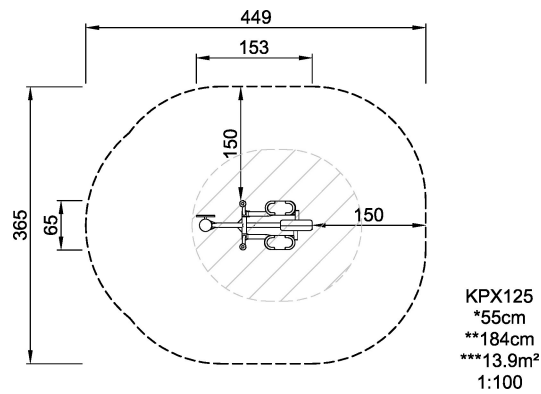

KPX125  
1:100

\* = Highest designated play surface.  
\*\* = Total height of product.

<b>Weight/heaviest parts</b>	kg.	<b>Installation (Manpower)</b>	1 Persons
<b>Concrete required</b>	NaN m <sup>3</sup>	<b>Installation (Hours)</b>	3 Hours
<b>Foundation amount/footing</b>	NaN	<b>Excavation</b>	NaN m <sup>3</sup>