

MSC6428

KOMPAN Ugly Duckling and Tinderbox

KOMPAN[®]
Let's play



The climbing wall and easy access invite climbers to choose their own way to reach the top. The climbing wall challenges children's problem solving abilities and is suitable for different skill levels - the left side is an easier route than the right. There is a fun slide leaving from the ship side and on balcony on the other side children can quickly slide down the fireman's pole descending from the castle. The Ugly Duckling facade has a waste number manipulative element like a small scale, nest with moveable eggs and chicken. Also the main character the Ugly Duckling with turntable wing and egg laying hens are on the facade. Children will be delighted to find to different shelters underneath the structure, one where they can look out of through the jail bars or play within the farm shop dens at the other end of the structure, which also have a little bench. The bench can be used as a counter for constructive play or as a place to just sit. On the other side with the Tin Soldier the children will also have a huge number of tactile and manipulative features like rubber roots which gives access to the shelter below the structure. A moveable padlock makes it possible to lock and unlock the jail house. A treasure chest with coins can be open and closed and next to the chest there is a witch with a tactile stick.

Product Line	Themed Play
Category	THE SMART PLAYGROUND™ (Digital)
Age group	2 - 6
Max. fall height (CM)	137
Total height (CM)	369
Safety Zone	32.3 m2



**SUR-
FACE**

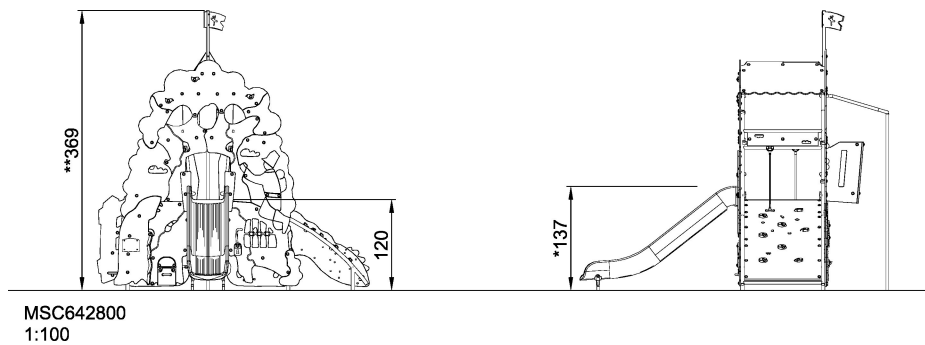
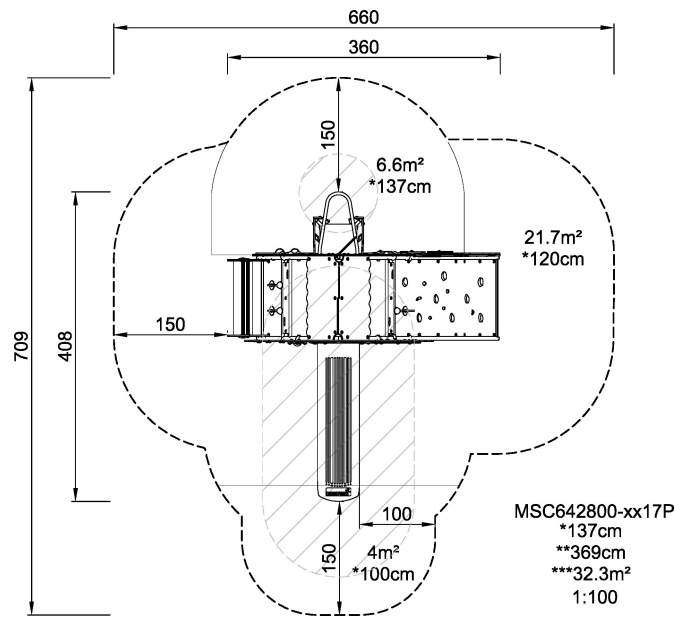

* = Highest designated play surface.
** = Total height of product.

Weight/heaviest parts	kg.	Installation (Manpower)	Persons
Concrete required	NaN m ³	Installation (Hours)	Hours
Foundation amount/footing	NaN	Excavation	NaN m ³