

MSV605 Low Slope



The low slope is a great physical play unit that can be climbed, crawled, slid, and lied on also by the younger toddlers. Crawling, climbing or walking on slopes is a fantastic training of the child's vestibular system and kinesthetic: the training of cross-coordination, of balance, proprioception and spatial relations is made in a fun and active way. A Play Book text with curriculum supportive games, made by the KOMPAN Play Institute, can be ordered.

Product Line	Themed Play
Category	Toddler play for supervised areas
Age group	1 - 4
Max. fall height (CM)	28
Total height (CM)	38
Safety Zone	12.8 m ²



INCLUSIVE



**SUR-
FACE**



ADA / INCLUSIVE

ASTM

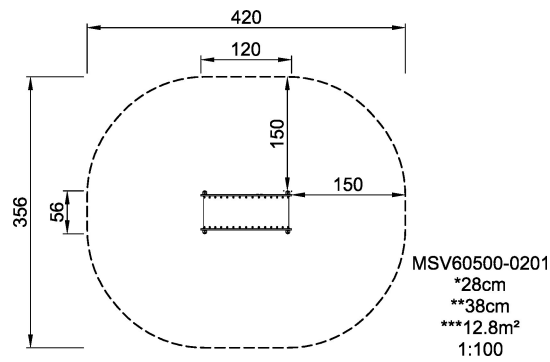

* = Highest designated play surface.
** = Total height of product.

Weight/heaviest parts	kg.	Installation (Manpower)	Persons
Concrete required	NaN m ³	Installation (Hours)	Hours
Foundation amount/footing	NaN	Excavation	NaN m ³