

# MSV606 Steep Slope



The Steep Slope is a great physical play unit that can be climbed, crawled, walked, slid, and lied on also by the younger toddlers. Crawling, climbing or walking on slopes is a fantastic training of the child's vestibular system and kinesthetic: the training of cross-coordination, of balance, proprioception and spatial relations is made in a fun and active way. A Play Book text with curriculum supportive games, made by the KOMPAN Play Institute, can be ordered.

<b>Product Line</b>	Themed Play
<b>Category</b>	Toddler play for supervised areas
<b>Age group</b>	1 - 4
<b>Max. fall height (CM)</b>	41
<b>Total height (CM)</b>	51
<b>Safety Zone</b>	12.8 m <sup>2</sup>



INCLUSIVE



**SUR-  
FACE**



ADA / INCLUSIVE

**ASTM**

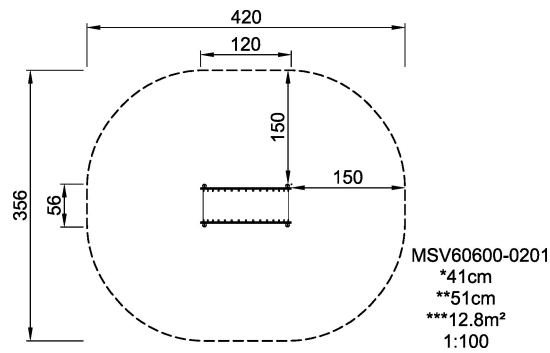

\* = Highest designated play surface.  
\*\* = Total height of product.

<b>Weight/heaviest parts</b>	kg.	<b>Installation (Manpower)</b>	Persons
<b>Concrete required</b>	NaN m3	<b>Installation (Hours)</b>	Hours
<b>Foundation amount/footing</b>	NaN	<b>Excavation</b>	NaN m3