

PLAYHUT W/ SIDE+GABLE+DESKS



NRO414

KOMPAN
Let's play



Item no. NRO414-1031

General Product Information

Dimensions LxWxH	180 x 163 x 158 cm
Age Group	6m+
Play Capacity	12 children
Colour Options	 



Wow! This attractive playhut inspires children to play together in both creative and imaginative ways. The open-ended design encourages themed and imaginative play within and around the playhut. Children will want to play longer due to the simple yet intentional design and the detail in its play features. The roof provides a sheltered space allowing the children to move

in and out of the playhut while using their imagination. The small window will support play on all sides of the playhut and encourage hide and seek games. Playing social games helps a child with their developmental. The bench adds a space to take a break and the desks provide more space for being creative. The open window allows for

exchanges from in and outside. All of these activities support a healthy development through play.



Data is subject to change without prior notice.

PLAYHUT W/ SIDE+GABLE+DESKS

NRO414



All Organic Robinia products by KOMPAN are made of 100% Robinia wood. On request the products can be supplied with 100% FSC™ certification of the wood.



Products are PREASSEMBLED from the factory to ensure all safety requirements are considered.



The paint used for coloured components is water based environmentally friendly with excellent UV resistance. The paint is in compliance with EN 71 Part 3.

Item no. NRO414-1031	
Installation Information	
Max. fall height	- cm
Safety surfacing area	17,2 m ²
Numbers of Installers (persons)	2
Total installation time	7
Excavation volume	0,63 m ³
Concrete volume	0 m ³
Footing Depth (Standard)	100 cm
Shipment Weight	300 kg
Anchoring options	In-ground ✓ Surface ✓
Warranty information	
Robinia wood	15 Years
Stainless steel hardware	Lifetime
Galvanised steel	10 Years
EcoCore™ HDPE	Lifetime
Spare parts guaranteed	10 Years



The playhouses are available with floor inside the house and with a floor outside to create a porch.



There are Multiple footing options for all products: Surface anchoring with steel footings and expansion bolts. Wood in-ground or steel in-ground footings.



The Robinia can be supplied with different surface treatment: Untreated Robinia wood, Brown transparent paint and Coloured components.



PLAYHUT W/ SIDE+GABLE+DESKS

NRO414

Max fall height | Total height | Safety surfacing area

Max fall height | Total height

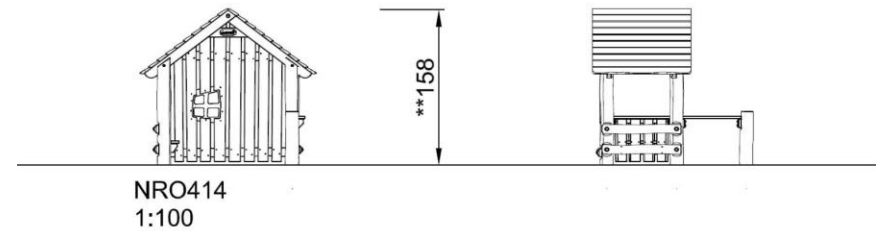
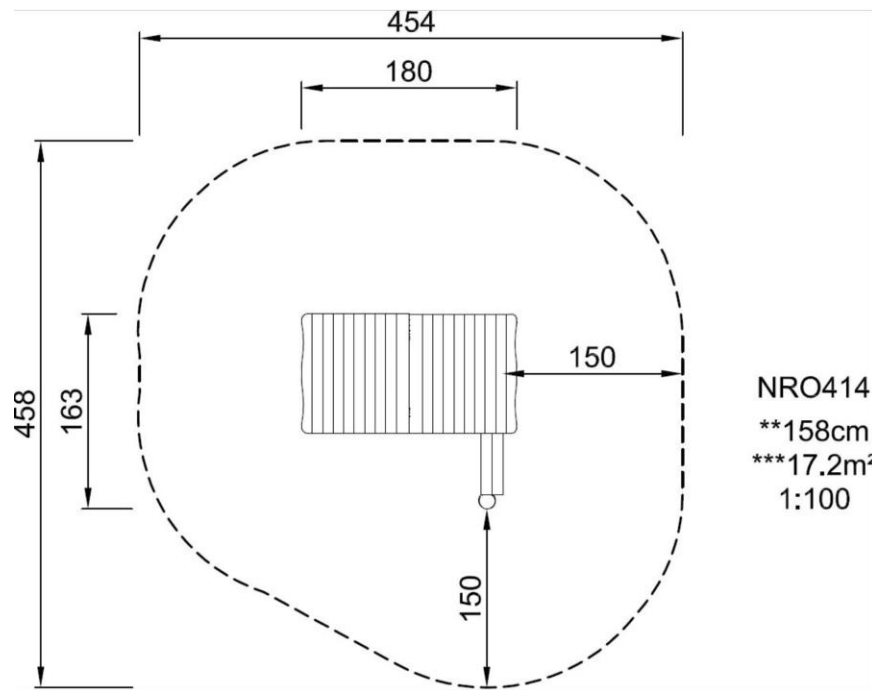

[Click to see 1:100 ratio TOP VIEW](#)

[Click to see 1:100 ratio SIDE VIEW](#)

PLAYHUT W/ SIDE+GABLE+DESKS

NRO414



Roof

Cognitive: suggests a theme and supports dramatic play, which stimulates languages and communication skills.



Window

Social-Emotional: invites interaction between sides and cooperative play.



Bench

Social-Emotional: gathering, cooperating or taking a break from play - all train social skills.



Desk

Social-Emotional: great meeting place and space creator for storing or sitting.

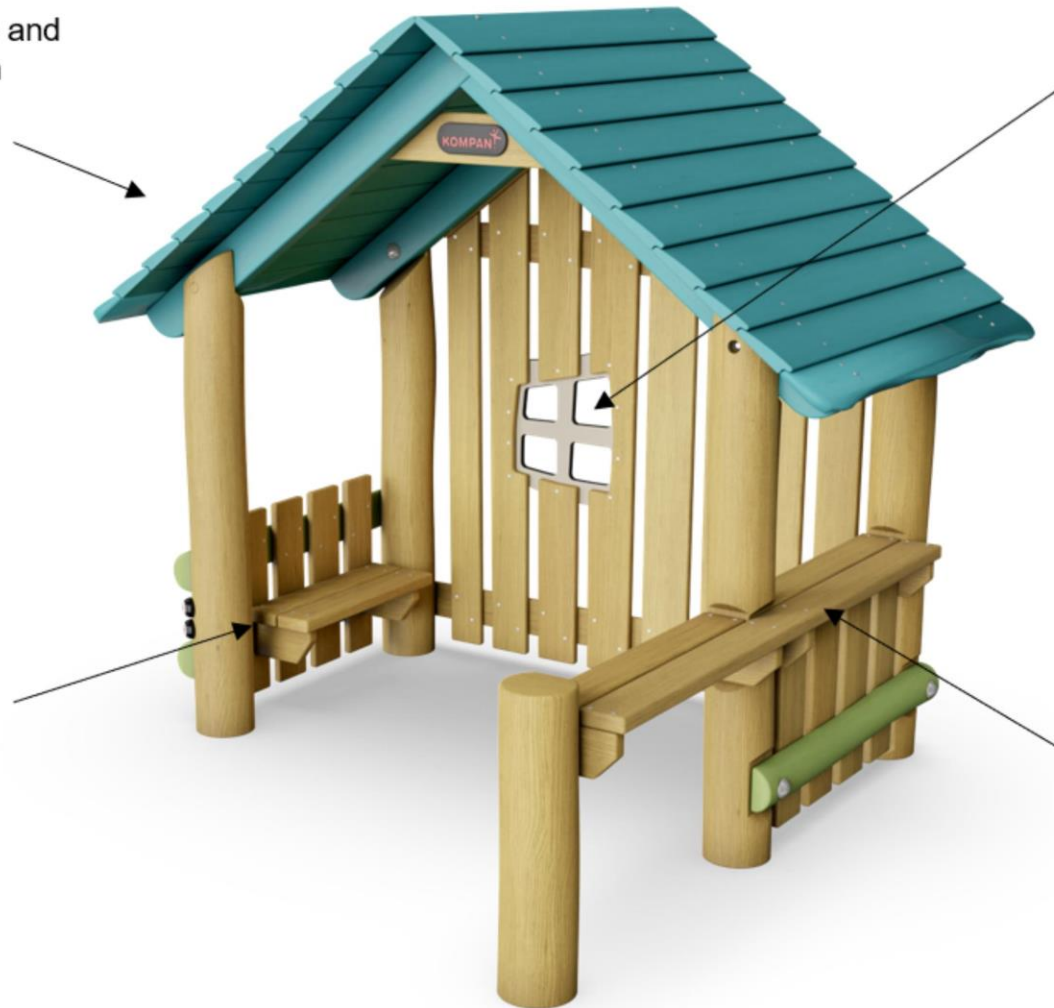

PLAYHUT W/ SIDE+GABLE+DESKS

NRO414



PHYSICAL
Joy of movement:
motor skills, muscle, cardio
and bone density



SOCIAL-EMOTIONAL
Joy of being together:
teamwork, tolerance and
sense of belonging



COGNITIVE
Joy of learning:
curiosity, understanding of causal
relationships and knowledge of the world



CREATIVE
Joy of creating:
co-creation and experimenting
with materials



BALANCE
To balance is to stay upright when walking or standing on a surface that makes this challenging (e.g. a wobbly, inclined, or narrow surface).



HANG IN ARMS
To hang in arms is the act of carrying the body with the hands or arms, possibly to traverse to another platform or play item.



SENSORY
To sense is the act of taking in information with the sensory system: seeing, feeling, hearing or sensing with the body.



BOUNCE
To bounce is the act of bouncing on a responsive, flexible, elastic or tensile surface.



JUMP
To jump is the act of jumping up or down on a hard surface.



SLIDE
To slide is the act of moving fast downwards seated on a slide.



CLIMB
To climb is the act of moving upwards, cross-coordinating arms and legs, on a vertical or inclined surface or net.



PULL
To pull is the act of pulling an item towards you or you towards an item with one or both hands, or possibly using the entire body.



SOCIALIZE
To socialize is the act of meeting, communicating or cooperating in an activity that stimulates and facilitates social interaction.



CONSTRUCT
To construct is the act of creating new patterns, shifting items or materials to new positions or constructing with materials that can be transformed or manipulated.



PUSH
To push is the act of pushing an item away from you with one or both hands, possibly with the entire body.



SPIN
To spin involves a fast, repeated horizontal or vertical turn of the body on a piece of equipment that facilitates the movement.



CRAWL
To crawl is the movement of moving forwards or backwards, cross-coordinating arms and legs, on a horizontal or slightly inclined surface.



ROCK
To rock is the action of rocking back and forth, or sideways, on e.g. a piece of spring equipment.



SWAY
To sway is the movement of swaying back and forth, or around, lying, seated or possibly standing, in a pendulant or circular movement, e.g. on a hammock or on a rope.



DRAMATIC PLAY
Dramatic play is motivated through play items that stage a frame, place or environment for acting out make believe or role play scenarios.



ROTATE
To rotate involves a vertical or horizontal slower paced turn of the body, facilitated by a piece of equipment.



SWING
To swing is the movement of swinging back and forth, or in circular movement, seated, standing or lying, in an unhindered arc.



GLIDE
To glide is the act of moving from one point to another without shifting the feet, in a horizontal or vertical movement, in a seated, lying or standing position, letting gravity do the work.



RULES PLAY
Rules play is motivated through play items that suggest games-with-rules, cooperation and team work, e.g. tic-tac-toe, timers or ball games.



WONDER
To wonder is motivated through play items that make children need and use their logical, abstract or creative thinking skills, as well as their memory.