



With a world of thrilling climbing, sliding and swaying activities, the Silberhorn attracts children time after time, thanks to the wide variety of challenges and meeting points. There are banister bars for gliding, curved slide for a different sliding experience, play shells and climbing walls for cross-body coordination and muscle strength and rubber pods for balance training. A twisted net and swaying play shells in the middle add attraction. All of these activities train muscles as well as the motor skill ABC, agility, balance and coordination. These are important for the child's ability to concentrate, as well as life skills like navigating traffic securely. The challenge of the activities, like climbing high, stimulates the children's self-esteem. The openness of design and the layers of play challenge offers activity and interaction for all.

<b>Product Line</b>	ELEMENTS™
<b>Category</b>	ELEMENTS™ GO
<b>Age group</b>	6+
<b>Max. fall height (CM)</b>	243
<b>Total height (CM)</b>	550
<b>Safety Zone</b>	66 m2



SENSORY



JUMP



HANG IN ARMS



BALANCE



CLIMB



SLIDE



SOCIALIZE



SWAY



GUIDE



PULL



RULES PLAY



**SUR-  
FACE**

**IN-  
GROU.**

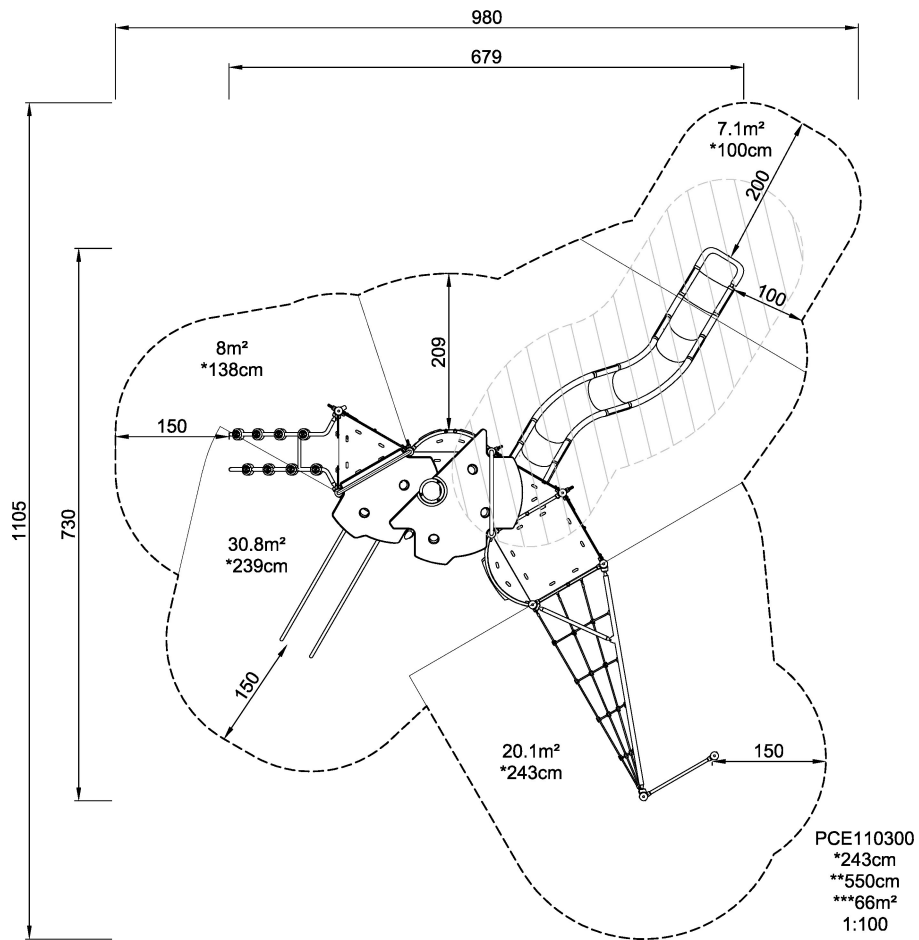

PCE110300  
\*243cm  
\*\*550cm  
\*\*\*66m<sup>2</sup>  
1:100

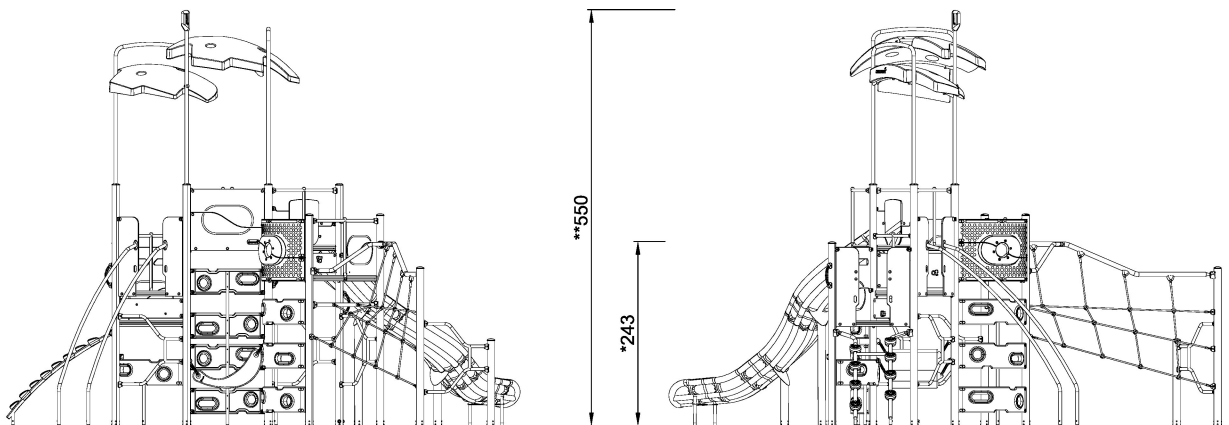

PCE110300  
1:100

\* = Highest designated play surface.  
\*\* = Total height of product.

<b>Weight/heaviest parts</b>	kg.	<b>Installation (Manpower)</b>	Persons
<b>Concrete required</b>	NaN m3	<b>Installation (Hours)</b>	Hours
<b>Foundation amount/footing</b>	NaN	<b>Excavation</b>	NaN m3