

The whimsical look of the Rider attracts children's curiosity. Irresistible, they just have to try it out! Due to the fine sensory and gross motor activities of the Rider, retention is ensured: the density of play activities in a cosy space is obvious. By the children or adults pushing or pulling, the Rider can be turned to face different ways. This trains major muscles and the spatial awareness. It also provides variety in play. The seat in the middle also functions as a table, and the steering wheel turns it into a vehicle, stimulating the children's imagination. The huge rounded window not only provides a great lookout to the outside, it also distorts the sound of the voice, a great attraction and cause and effect function, developing the children's logical thinking.

Product Line	ELEMENTS™
Category	ELEMENTS™ GROW
Age group	2+
Max. fall height (CM)	30
Total height (CM)	237
Safety Zone	15.2 m ²



WONDER



SENSORY



CRAWL



HANG IN ARMS



ROTATE



CONSTRUCT



SOCIALIZE



PULL



PUSH



DRAMATIC PLAY



INCLUSIVE



SUR-
FACE

IN-
GROU.



ADA / INCLUSIVE

ASTM

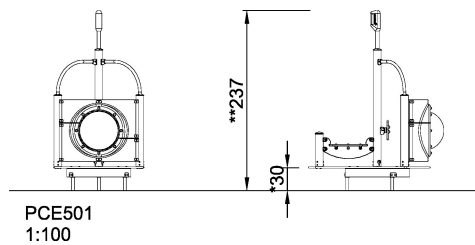
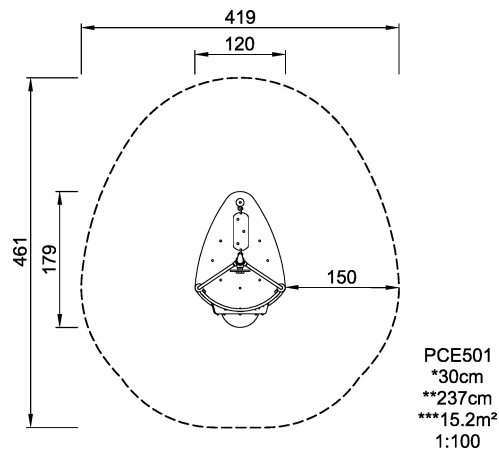

* = Highest designated play surface.
** = Total height of product.

Weight/heaviest parts	kg.	Installation (Manpower)	Persons
Concrete required	NaN m ³	Installation (Hours)	Hours
Foundation amount/footing	NaN	Excavation	NaN m ³