

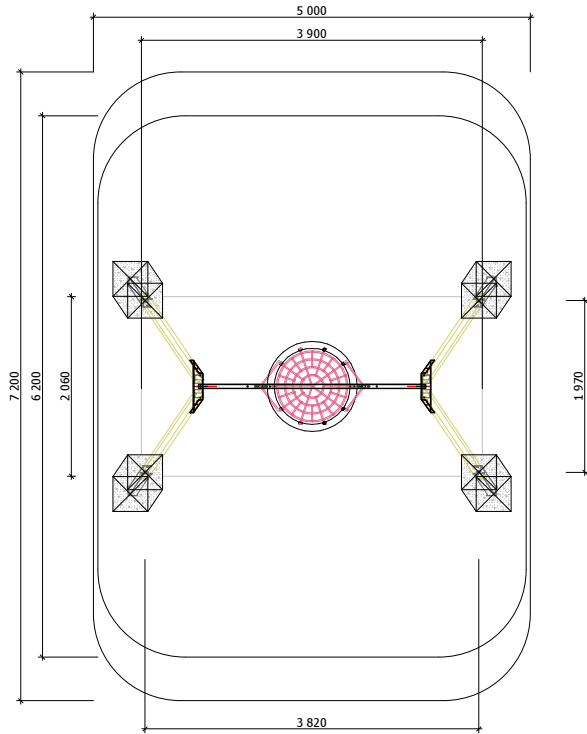

Construction are made from glued wood, galvanized steel and HDPE.

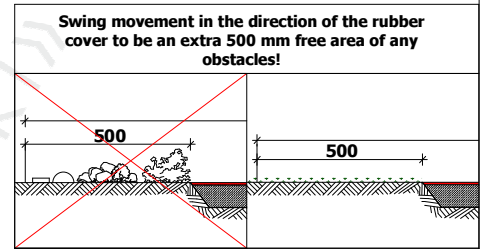

- MAX**
5 children
- AGE**
Children from 2 - 14 years
- The Fall height**
H=1.275 m
- Weight**
114 kg
- Assembly**
4.5 h (without excavation and concreting)



Equipment safety checkings must be performed once in a week in high vandalism risk areas.
Maintenance are required once in every 3 months, depending on usage

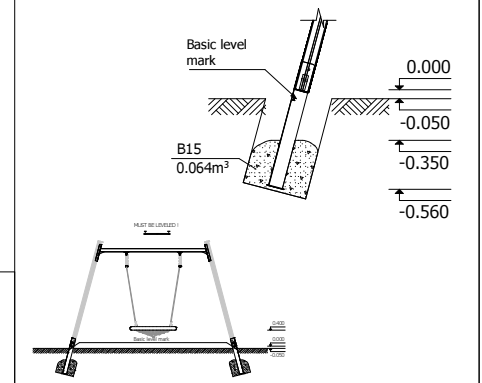

Minimal required area - 28 m²

Length: 3 900 mm
Width: 2 060 mm
Height: 2 230 mm

Playground are provided for outdoor use in supervising of adults

Length of safety area: 5 000 mm
Width of safety area: 7 200 mm
Required safety area: 33 m²

Play equipment are established with concreted steel foundation in equipment location. Equipment are suitable for use in two days after concreting, when the foundation are totally solid. During assembling there are not children allowed in area.

Adequate temperature

T_{min} - 33.2 °C
T_{max} +70.1 °C



Snow load

Small



Wing load

Small

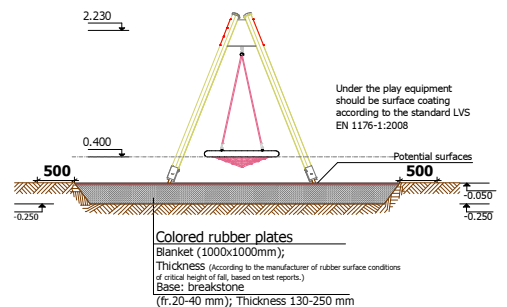
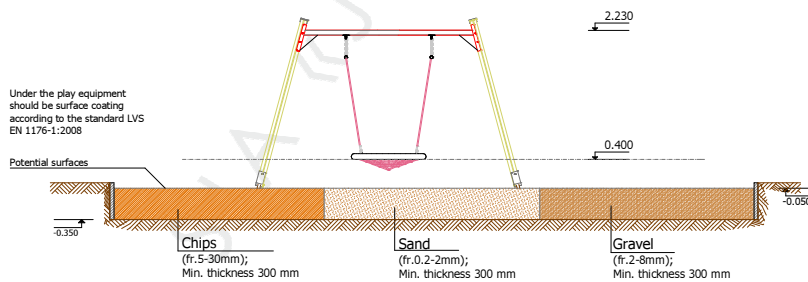

Transportation: A pallet: one pallet 2600 x 1000 x 400 mm (If Number of greater than 1000 mm)
One lay and one package: 1 pallet 2600 x 1000 x 400 mm, 1 pack - Number)

Spare parts: All needed spare parts and elements, when warranty time expires can be ordered in „Jūrmalas Mežaparki” Ltd, and all the goods will be ready for delivery in 3 days.

According to LVS EN 1176:2008

Manufactured according to:

