

# Workout Parallel bars

ref. SW003DI

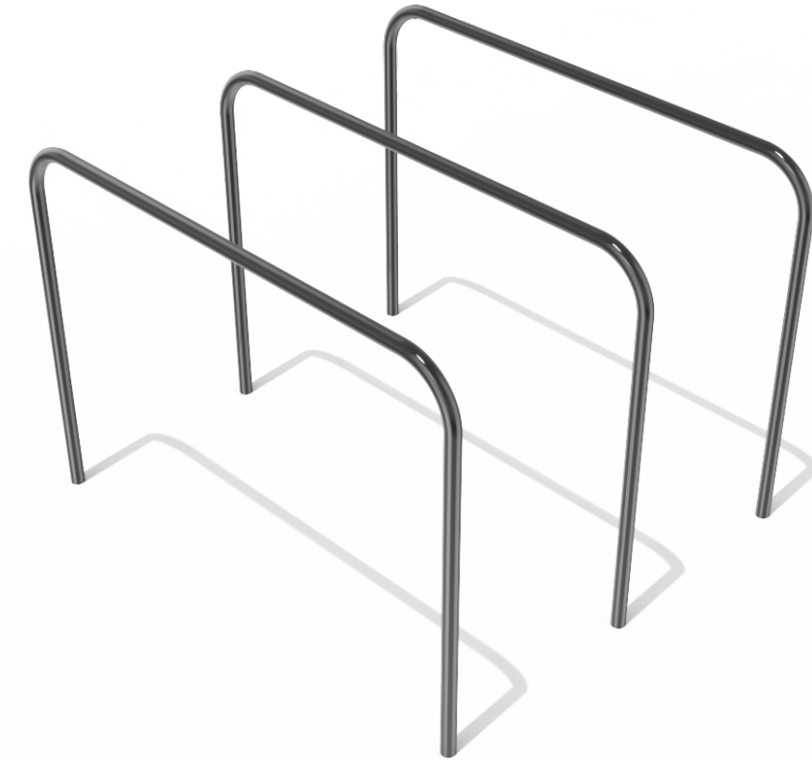

**+12 Years**

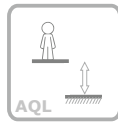

**1.17 m**

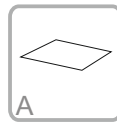

**20 m<sup>2</sup>**

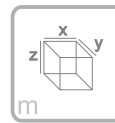

**x= 1.54  
y= 1.52  
z= 1.17**

Data Sheet

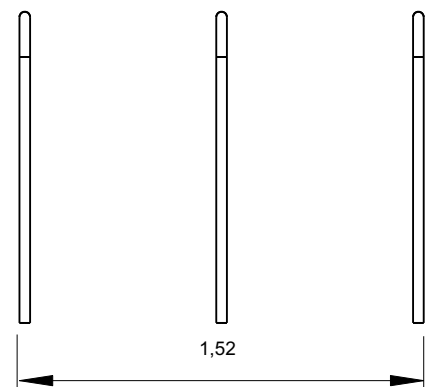
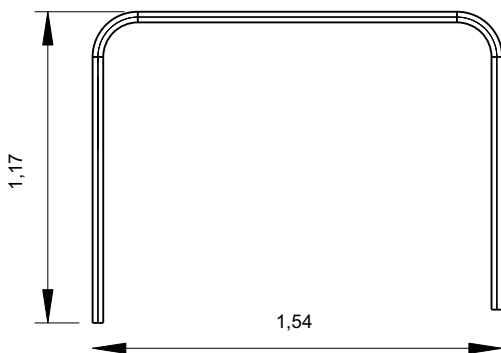



# Equipment Information:

— Impact area  
 - - Free space

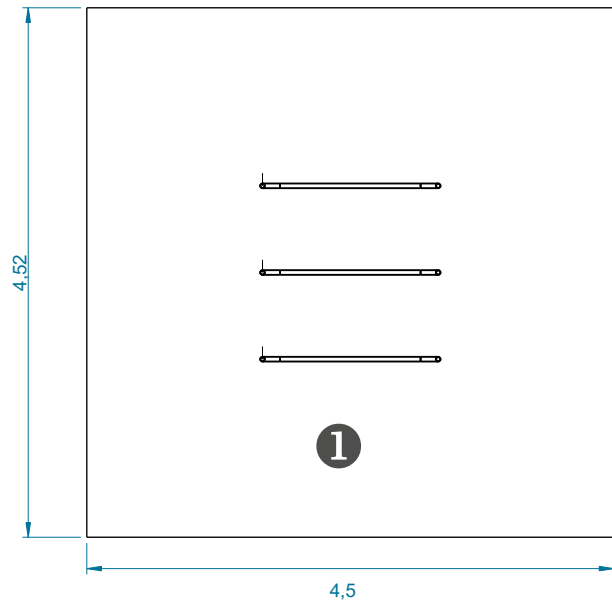
EN 1176-1





.....	①
	1,17
	20
	20

0,2 m<sup>3</sup>



6h



2x



KG



KG



# Technical Information:

1 - Parallel Bars  1.17m

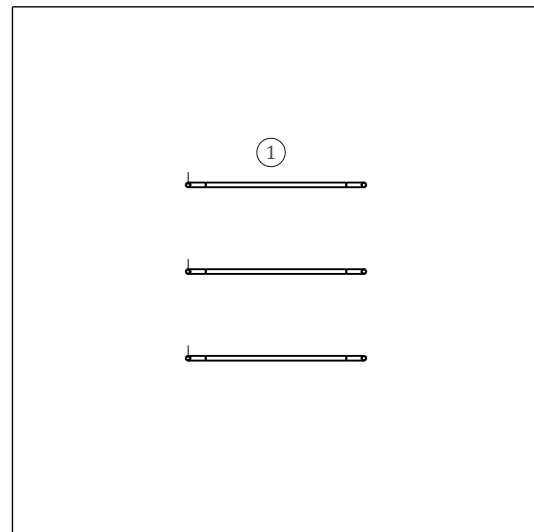

# Technical Characteristics:

## Metal Parts

### Tubes:

**Stainless steel:** AISI 304, Ø40mm;

### Fixation System:

**Type C - Standard fixation system** composed by posts applied directly in the ground with concrete;



100% recyclable;

