

10031 BIRD'S NEST SWING



TECHNICAL DATA:

Device dimensions:	1,92m x 3,50m
Device height:	2,40m
Minimum space:	7,40 x 3,50m
Falling area:	25,90m ²
Critical fall height:	1,25m
Depth of foundations:	-0,60m

Top view with falling area:

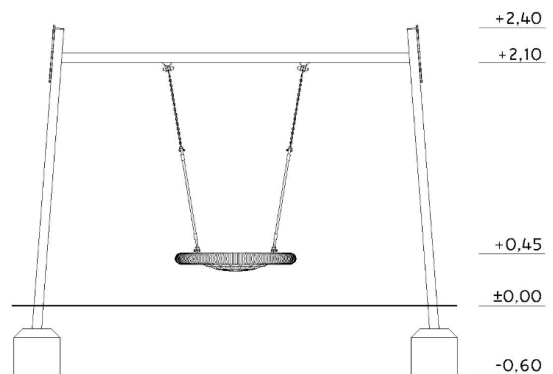
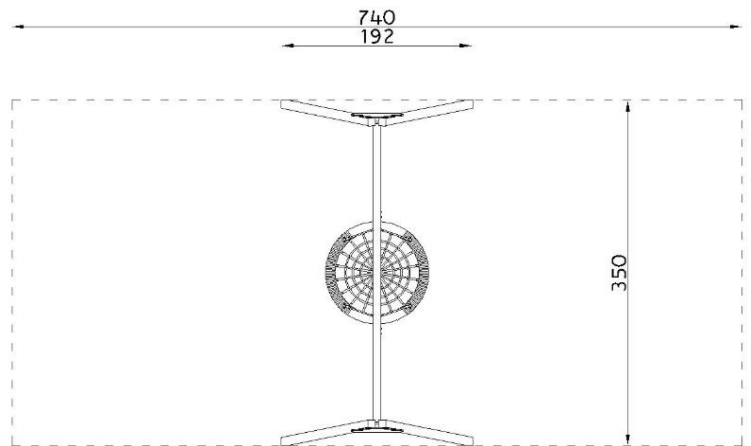

The device according to EN 1176-1:2012
 Playground equipment and surfacing – Part 1:
 General safety requirements and test methods.

Safety surfaces:

- turf/topsoil, sand, gravel, bark, synthetic surface
- minimal thickness for loose particulate materials 200+100mm
- synthetic surface according to critical fall height

MATERIALS:

Construction poles:	pine wood glued in layers, rounded at the edges, coated with acrylic glaze
Anchors:	galvanized steel
Steel elements:	galvanized steel powder coted
Seats:	made of polypropylene ropes with a steel braid
Decorative elements:	HDPE sheet
Chain:	galvanized steel,
Caps :	plastic,
Foundations:	concrete class min. C12/15



SATERNUS DISTRIBUTION Sp. z o.o. sp.k.
ul. Nowa 32
41-500 Chorzów, Poland

Certificate beholder:
Producer:
Distributor:

GRUPA SATERNUS Sp. z o.o. S. K. A. reserves all rights to protect copyright under the Act of February 4, 1994 on Copyright and Related Rights (Journal of Laws No. 28, item 83), and in particular Art. 78 and 79 of this Law.

GRUPA SATERNUS Sp. z o.o. S. K. A.
Saternus Production Sp. z o.o. sp. k.
Saternus Distribution Sp. z o.o. sp. k.