

## 30030 SINGLE PENDULUM SWING



### TECHNICAL DATA:

<b>Device dimensions:</b>	1,92m x 2,25m
<b>Device height:</b>	~2,40m
<b>Minimum space:</b>	7,40 x 2,25m
<b>Critical fall height:</b>	1,25m
<b>Falling area:</b>	16,65m <sup>2</sup>
<b>Depth of foundations:</b>	-0,60m

Top view with falling area

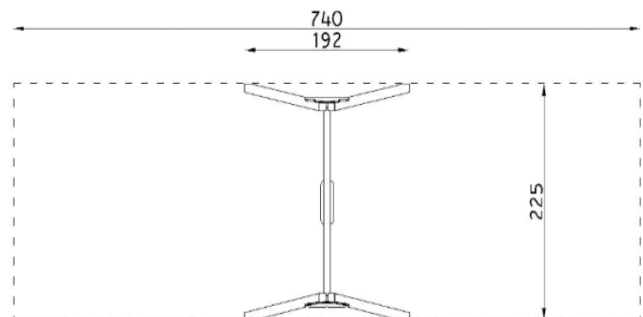

The device according to EN 1176-1:2012  
 Playground equipment and surfacing – Part 1:  
 General safety requirements and test methods

#### Safety surfaces:

- turf/topsoil, sand, gravel, bark, synthetic surface
- minimal thickness for loose particulate materials 200+100mm
- synthetic surface according to critical fall height

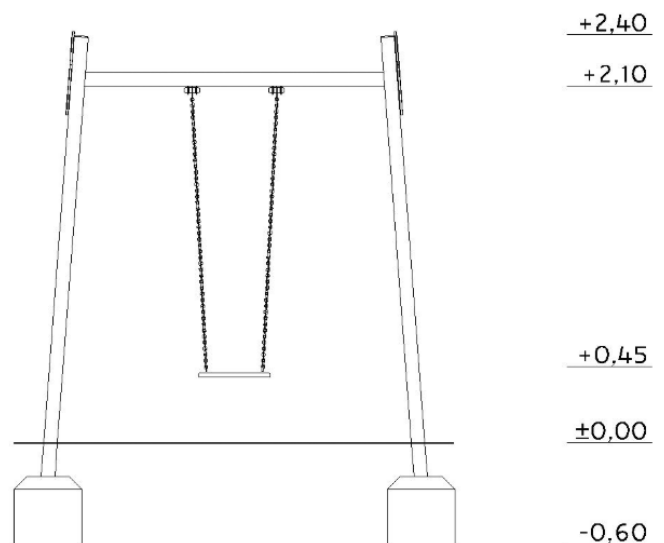

## MATERIALS:

<b>Construction poles:</b>	glued pine wood, rounded at the edges, coated with acrylic glaze
<b>Anchors:</b>	steel galvanized
<b>Steel elements:</b>	steel galvanized, powder coated
<b>Seats:</b>	made of steel structure coated with rubber
<b>Decorative elements:</b>	HDPE sheet
<b>Chain:</b>	galvanized steel,
<b>Caps:</b>	plastic
<b>Foundations:</b>	concrete class min. C12/15



SATERNUS DISTRIBUTION Sp. z o.o. sp.k.  
ul. Nowa 32  
41-500 Chorzów, Poland

Certificate beholder:  
Producer:  
Distributor:

GRUPA SATERNUS Sp. z o.o. S. K. A. reserves all rights to protect copyright under the Act of February 4, 1994 on Copyright and Related Rights (Journal of Laws No. 28, item 83), and in particular Art. 78 and 79 of this Law.

GRUPA SATERNUS Sp. z o.o. S. K. A.  
Saternus Production Sp. z o.o. sp. k.  
Saternus Distribution Sp. z o.o. sp. k.