

Construction are made from glued wood, galvanized steel and HDPE.

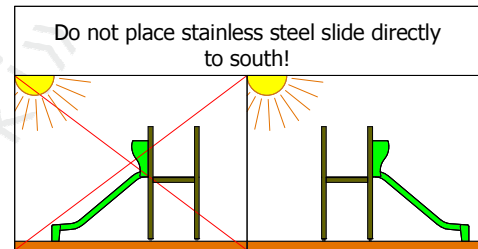
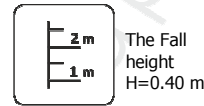
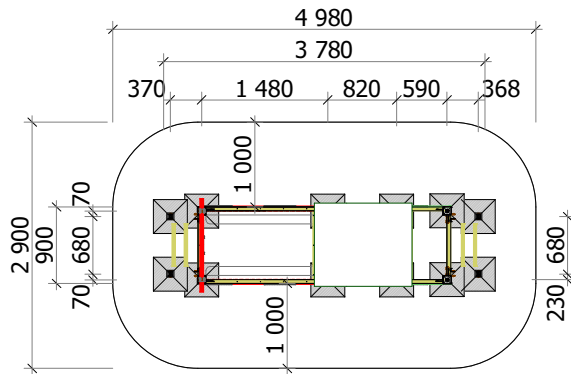
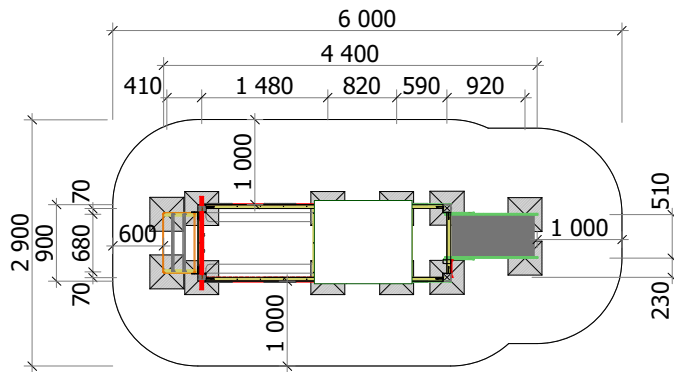

Equipment safety checkings must be performed once in a week in high vandalism risk areas.

Maintainance are required once in every 3 months, depending on usage

Minimal required area - 16 and 14 m²

Length: 4 400 mm / 3 780 mm
Width: 900 mm / 900 mm
Height: 1 780 mm / 1 780 mm

Playground are provided for outdoor use in supervising of adults

Length of safety area: 6 000 mm / 4 980 mm
Width of safety area: 2 900 mm / 900 mm
Required safety area: 16 m² / 14 m²

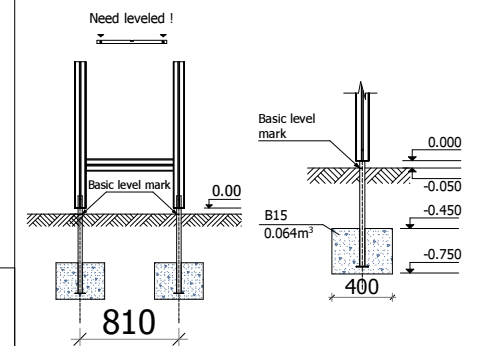

Play equipment are established with concreted steel foundation in equipment location. Equipment are suitable for use in two days after concreting, when the foundation are totally solid. During assembling there are not children allowed in area.

Adequate temperature

T_{min} -33.2 °C
T_{max} +70.1 °C



Snow load

1.22 kN/m²



Wing load

Strength 753.3 N

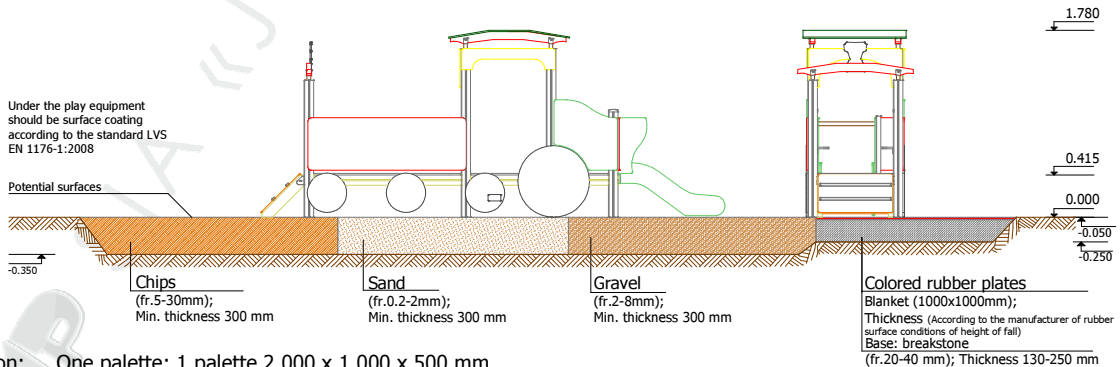

Transportation: One palette: 1 palette 2 000 x 1 000 x 500 mm

Spare parts: All needed spare parts and elements, when warranty time expires can be ordered in „Jūrmalas Mežaparki” Ltd., and all the goods will be ready for delivery in 3 days.